

LIB System for UPS

Installation Manual

(128S)

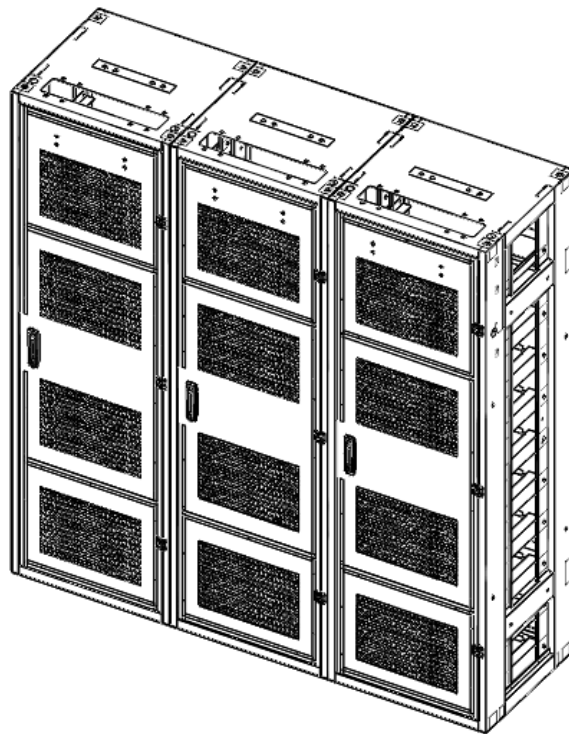

***Read this manual carefully before starting to install the battery system.
Keep these instructions for future reference.***

Copyright © 2016 SAMSUNG SDI Co., Ltd. All rights reserved.





This document contains information that is the property of SAMSUNG SDI Co., Ltd., and provides for the sole purpose of the installation, operation, and maintenance of products of SAMSUNG SDI Co., Ltd. No part of this publication is to be used for any other purpose, and it is not to be reproduced, copied, disclosed, transmitted, stored in a retrieval system, or translated into any human or computer language, in any form, by any means, in whole or in part, without prior written consent of SAMSUNG SDI Co., Ltd.

Although every possible effort has been made to ensure the accuracy of this document, SAMSUNG SDI Co., Ltd. assumes no responsibility for errors that may appear herein. The information is subject to change without notice.

Important Safety Instructions

Read and follow these instructions!

The following precautions are intended to ensure your safety and prevent property damage. Before installing this product, be sure to read all safety instructions in this document for proper installation.

	DANGER Failure to comply with the instructions with this symbol may result in a serious accident, causing death or a severe injury.
	WARNING Failure to comply with the instructions with this symbol may result in a serious accident, causing a severe injury.
	CAUTION Failure to comply with the instructions with this symbol may result in minor or moderate injury.
	NOTICE Provides information considered important but not hazard-related. The information relates to property damage.
	Important Indicates valuable tips for optimal installation and operation of the product.

General Instructions

Please be aware that a battery presents a risk of electrical shock including high short-circuit current. Follow all safety precautions while operating the batteries.

- Remove watches, rings, and other metallic accessories.
- Use tools with insulated handles in order to avoid inadvertent short circuits.
- Wear rubber gloves and safety boots.
- Do not put tools or any metal parts on the top of the batteries.
- Disconnect charging source and load before connecting or disconnecting terminals.
- Use proper lifting means when moving batteries and wear all appropriate safety clothing and equipment.
- Batteries must be handled, transported and recycled or discarded in accordance with federal, state, and local regulations. Do not dispose of the batteries in a fire because they can explode.
- Do not open or mutilate the batteries.
- Only authorized, trained technicians should perform annual preventive maintenance.
- Only qualified personnel who are familiar with the batteries and safety precautions should perform installation or maintenance of the battery.
- Do not allow unauthorized personnel to contact the batteries.

Safety Precautions

The following precautions provide general safety guidelines that should be followed when working with or near the Energy Storage System (ESS). Complete safety parameters and procedures are site-specific and should be developed by the customer for the installation site.

- Review and refer to all safety warnings and cautions in this manual before installation.
- Build a clear, permanent, restricted access area around the system.
- Only authorized, adequately trained electrical operators should be able to access the system.

The interior design of this equipment must be considered a “no-go area except for non-qualified personnel who are familiar with the batteries and safety precautions,” depending on the location. Consult local codes and applicable rules and regulations to determine permit requirements. If required, mark enclosures appropriately before beginning work.

Personnel and Equipment Warnings

Personnel in contact with the battery system should be aware of the following hazards:



WARNING—SHOCK HAZARD

Do not contact system connectors or terminals. Do not open the enclosure doors unless proper lock out/tag out procedures and related trainings are followed in accordance with the local codes and regulations.



WARNING—ARC FLASH HAZARD

There is an arc flash hazard associated with all electrical equipment. There is a serious risk of arc flash relating to any equipment modification (e.g. opening doors). Serious injuries can occur in arc flash incidents. Appropriate training is required in accordance with local codes and regulations.



WARNING—FIRE HAZARD

Fire may occur under certain fault conditions.



CAUTION—PINCH POINTS

Multiple pinch-points are present in most system components. Be aware that there is a serious risk of injury while working around and in equipment enclosures.



CAUTION—STATIC SENSITIVE

Electronic appliances can be damaged by electrostatic discharge. Proper handling procedures are required. Be sure to wear a grounded anti-static wrist strap and to discharge static electricity by touching a grounded surface near the equipment before touching any system components.

Dangerous Voltages



DANGER

The ESS is powered by multiple power sources. Hazardous voltages may be present in the equipment even when it does not appear operational. Make sure that you completely understand the cautions and warnings in this installation manual. Failure to do so may result in serious injury or death. Follow all manufacturer-published safety procedures.

Electrical equipment can present a risk of electrical shock and can cause arc flash. The following precautions must be observed when working on or around electrical equipment:

- Remove watches, jewelry, rings, and other metallic objects.
- Use tools with insulated handles.
- Safety clothing and shoes must comply with local codes and regulations.

Lock Out/Tag Out Guidelines



DANGER

Follow all applicable lock out/tag out procedures at all times. Failure to follow proper lock out/tag out procedures may result in serious injury or death.

With power applied to the ESS, hazardous voltages are present on some components. To prevent accidental death or injury, do not touch any components within the enclosure unless you are specifically directed to do so. To reduce the risk of electrical shock, make sure that all equipment is properly grounded..”



WARNING

Enclosure doors must remain closed except when access to the enclosure interior is required. If possible, personnel should keep a safe distance from enclosures whenever the equipment is energized. Always comply with local, state, and national lock out/tag out guidelines when working with or near the ESS. The lock out/tag out procedures must meet or exceed the requirements of all guidelines presented in SAMSUNG SDI safety documentation. Before entering potentially hazardous areas or beginning work on the ESS, complete the following tasks:

- Identify and wear protective clothing and shoes.
- Identify and isolate all power and stored energy sources.
- Apply appropriate lock out/tag out devices. When applying lock out/tag out to the ESS, do not touch anything within the enclosure except as specifically directed in the work procedures.
- Complete the site-specific lock out/tag out procedures and safety checklist before beginning work.

General Warnings



DANGER

When energized, this equipment presents a potential hazard of electric shock, death, and burn. Only authorized personnel who are thoroughly familiar with the equipment and adequately trained should install, operate, or maintain this equipment.



DANGER

To avoid death, personal injury, or damage to the product, follow all safety procedures as regulated by Environmental Health and Safety (EHS) guidelines.



DANGER

To minimize the hazards of electrical shock, death, and burns, approved grounding practices and procedures should be strictly followed.



WARNING

To avoid personal injury and damage to equipment, personnel must adhere to the site protocol concerning working at heights.

**WARNING**

To avoid personal injury or equipment damage caused by equipment malfunction, only adequately trained personnel should modify any programmable machine.

**WARNING**

Always ensure that applicable standards and regulations are followed and only properly certified equipment is used as a critical component of a safety system. Never assume that a safety-critical control loop is functioning correctly.

Table of Contents

Important Safety Instructions	i
General Instructions.....	ii
Safety Precautions	ii
Personnel and Equipment Warnings	iii
Dangerous Voltages	iii
Lock Out/Tag Out Guidelines.....	iv
General Warnings.....	iv
Table of Contents.....	i
Tables	iii
Figures	iv
1. About this Manual.....	1
1.1 Purpose	1
1.2 Target Audience	1
1.3 Organization	1
1.4 Revision History.....	2
1.5 Acronyms and Abbreviations	2
2. Installing the Product	4
2.1 Installation Procedure	5
2.2 Preparation Stage—Procedure.....	7
2.3 Preparation Stage—Unpacking	8
2.4 Preparation Stage—Ground Wire and Tools.....	9
2.4.1 Ground Wires	9
2.4.2 Ground Wire Fasteners	9
2.4.3 Rack Fasteners (Anchors).....	9
2.4.4 Multiple Rack Fasteners	9
2.5 Preparation Stage—Recommended Tools/Instruments	10
2.6 Preparation Stage—Visual Inspection	12
2.6.1 Inspecting the Rack Frame.....	12
2.6.2 Visual Inspection of the Modules	13
2.6.3 Inspecting the Switchgear	13
2.6.4 Inspecting the SMPS assembly.....	13
2.7 Rack Anchoring Stage	14
2.8 Rack Installation Stage	19
2.8.1 Battery Module Installation	20
2.8.2 Switchgear and SMPS Assembly Installation	23
2.8.3 Busbar Installation	27
2.8.4 Module and Switchgear Signal Cable Connection.....	37
2.8.5 Switchgear Signal Cable Connection for Rear-to-Rear Installation	48
2.8.6 SMPS Assembly and Switchgear Power Cable Connection.....	49
2.8.7 SMPS Assembly and Switchgear Signal Cable Connection	50
2.8.8 SMPS Assembly AC Input Connection	52
2.8.9 Rack Fuse and Additional Module Signal Cable Connection.....	54
2.8.10 DC Link Cable Connection	58
2.8.11 AC Input Commissioning.....	61
2.8.12 Switching On MCCB.....	61
2.8.13 BMS Configuration	63

2.8.14 Communication Check 75

Tables

Table 2-1: Estimated time for installation	6
Table 2-2: Parts for 128S 3P Rack	8
Table 2-3: Ground Wire Specification	9
Table 2-4: Ground Wire Fastener Specification	9
Table 2-5: Rack Fastener Specification	9
Table 2-6: Rack Fastener Specification (Side / Rear)	9
Table 2-7: Recommended Tools and Instruments	10
Table 2-8: Module Voltage and Internal Impedance	13
Table 2-9: Rack Clearance Distances	14
Table 2-10: Required Items for BMS Configuration	63
Table 2-11: Rack BMS ID Writing Cable Pin Map	64
Table 2-12: System BMS Configuration Cable Pin Map	65
Table 2-13: System BMS Communication Cable Pin Map	65

Figures

Figure 2-1: Installation Procedure.....	5
Figure 2-2: Faulty Cases	12
Figure 2-3: Clearance Distance for Single Rack Frame.....	15
Figure 2-4: Clearance Distance for Multiple Rack Frames	15
Figure 2-5: Clearance Distance for Multiple Rack Frames Installed Rear-to-Rear	16
Figure 2-6: Rack Anchoring Points (4 EA).....	16
Figure 2-7: Holes on the sides of the rack	17
Figure 2-8: Assembling Side Covers	17
Figure 2-9: Assembling Rear Covers.....	18
Figure 2-10: Insertion of Modules on the Ninth Shelf from the Bottom	20
Figure 2-11: Battery Module Arrangement on Eighth and Ninth Shelves.....	21
Figure 2-12: Battery Module Arrangement.....	21
Figure 2-13 : Module Number.....	22
Figure 2-14: Insertion of modules on 1 st shelf.....	22
Figure 2-15: Inserting Switchgear.....	23
Figure 2-16: Attaching a Switchgear Assembly to a Rack Frame	23
Figure 2-17: Ground Cable Connection to the Switchgear Assembly	24
Figure 2-18: Inserting SMPS Assembly.....	25
Figure 2-19: Attaching the SMPS Assembly.....	25
Figure 2-20: Ground cable connection to the SMPS Assembly	26
Figure 2-21: Removing the Front Covers.....	28
Figure 2-22: Connect Switchgear B- and Module #1 B-.....	28
Figure 2-23: Connect Module #1 B+ and Module #2 B-.....	29
Figure 2-24: Connect Module #2 B+ and Module #3 B-.....	29
Figure 2-25: Connect Module #3 B+ and Module #4 B-.....	30
Figure 2-26: Connect Module #4 B+ and Module #5 B-.....	30
Figure 2-27: Connect Module #5 B+ and Module #6 B-.....	31
Figure 2-28: Connect Module #6 B+ and Module #7 B-.....	31
Figure 2-29: Connect Module #7 B+ and Module #8 B-.....	32
Figure 2-30: Connect Module #9 B+ and Module #10 B-.....	32
Figure 2-31: Connect Module #10 B+ and Module #11 B-.....	33
Figure 2-32: Connect Module #11 B+ and Module #12 B-.....	33
Figure 2-33: Connect Module #12 B+ and Module #13 B-.....	34
Figure 2-34: Connect Module #13 B+ and Module #14 B-.....	34
Figure 2-35: Connect Module #14 B+ and Module #15 B-.....	35
Figure 2-36: Connect Module #15 B+ and Module #16 B-.....	35
Figure 2-37: Connect Switchgear B+ and Module #16 B+.....	36
Figure 2-38: Reassemble the Front Cover.....	36
Figure 2-39: Rack BMS to Module #1 OUT Signal Cable	37
Figure 2-40: Opening for Cable Installation	38
Figure 2-41: Module #1 to Module #2 Signal Cabling	38
Figure 2-42: Module #2 to Module #3 Signal Cabling.....	39
Figure 2-43: Module #3 to Module #4 Signal Cabling.....	39
Figure 2-44: Module #4 to Module #5 Signal Cabling.....	40
Figure 2-45: Module #5 to Module #6 Signal Cabling.....	40
Figure 2-46: Module #6 to Module #7 Signal Cabling.....	41
Figure 2-47: Module #10 to Module #11 Signal Cabling.....	41
Figure 2-48: Module #11 to Module #12 Signal Cabling.....	42
Figure 2-49: Module #12 to Module #13 Signal Cabling.....	42
Figure 2-50: Module #13 to Module #14 Signal Cabling.....	43
Figure 2-51: Module #14 to Module #15 Signal Cabling.....	43
Figure 2-52: Module #15 to Module #16 Signal Cabling.....	44
Figure 2-53: Pushed Hole Examples of Left Alignment of Switchgears.....	45
Figure 2-54: Signal Cabling Examples of Left Alignment of Switchgears	46
Figure 2-55: Openings for Cable.....	46
Figure 2-56: Termination Resistor Setting for Last Switchgear.....	47
Figure 2-57: Signal Cabling Example – Rear-to-rear connection on the right side	48
Figure 2-58: Signal Cabling Example – Rear-to-rear connection on the left side	48

Figure 2-59: DC Power Cables from SMPS Assembly Type A to Switchgear	49
Figure 2-60: CAN Signal Cable Connection from SMPS Assembly to Switchgear	50
Figure 2-61: TCP/IP Cable Connection to SMPS Assembly	50
Figure 2-62: Dry Contact Cable Connection to SMPS Assembly	51
Figure 2-63: MCCB Extra Auxiliary Connection	51
Figure 2-64: AC Input Terminals	52
Figure 2-65: AC Input Terminals with Cables Attached	52
Figure 2-66: AC Input Terminals Protective Covers	53
Figure 2-67: Remove Module #8 and Module #9 Front Cover	54
Figure 2-68: Rack Fuse Bus-bar Assembly	54
Figure 2-69: Rack Fuse Cover	55
Figure 2-70: Rack Fuse Cover (Fully Assembled Front View)	55
Figure 2-71: Assemble Module #8 and Module #9 Front Cover	56
Figure 2-72: Module #7 to Module #8 Signal Cabling	56
Figure 2-73: Module #8 to Module #9 Signal Cabling (WIRE ASSY MODULE TO MODULE #2)	57
Figure 2-74: Module #9 to Module #10 Signal Cabling	57
Figure 2-75: Grounding Points (2 EA)	58
Figure 2-76: Connection of Ground Cable for Multiple Rack Frames	58
Figure 2-77: Connecting the DC Link High Current Cables	59
Figure 2-78: MCCB Handle in Trip Position	61
Figure 2-79: MCCB Handle in Off Position	61
Figure 2-80: MCCB Handle in On Position	62
Figure 2-81: Rack BMS ID Writing Cable Pin Map	64
Figure 2-82: System BMS Configuration Cable Pin Map	65
Figure 2-83: System BMS Communication Cable Pin Map	65
Figure 2-84: Cable Connections for Rack BMS Configuration	67
Figure 2-85: Rack BMS CAN ID numbers for multiple rack system	67
Figure 2-86: Rack & System Monitoring Program	68
Figure 2-87: Monitoring Program Window	68
Figure 2-88: RACK BMS Installation Window	69
Figure 2-89: Displayed Window when Connected	69
Figure 2-90: Device box is empty when USB-to-CAN device is not connected	69
Figure 2-91: RACK BMS Installation Setting Window	70
Figure 2-92: Cable Connections for System BMS Configuration	71
Figure 2-93: Rack & System BMS monitoring program icon image	71
Figure 2-94: Communication Install Window	72
Figure 2-95: Install Window	72
Figure 2-96: System BMS Install Setting Window	73
Figure 2-97: Check System BMS Items	74
Figure 2-98: Open "Network"	75
Figure 2-99: Open "Network and Sharing Center"	76
Figure 2-100: Open "Change adapter settings"	76
Figure 2-101: Open "Properties" for "Local Area Connection"	77
Figure 2-102: Open Properties for "Internet Protocol Version 4(TCP/IPv4)"	77
Figure 2-103: Setting the IP address	78
Figure 2-104: System BMS monitoring program icon image	79
Figure 2-105: Main Window of Monitoring Program	79
Figure 2-106: Checking System BMS Data	80

1. About this Manual

To make sure that you understand the proper procedures for safe operation, this section briefly describes the purpose, audience, organization, revision history, and acronyms and abbreviations.

1.1 Purpose

The purpose of this manual is to provide information for the safe and successful installation of the product

The instructions in this manual are based on assembly of a three-cabinet system. Other configurations are possible and these instructions can be reduced or expanded to accommodate installation of those systems.

1.2 Target Audience

This installation manual is intended for system administrators and operators who install and configure the product.

1.3 Organization

This manual is composed of the following chapters:

- Chapter 1, "About this Manual," outlines this document.
- Chapter 2, "Installing the Product," explains how to install the product.

1.4 Revision History

Rev.	Description	Author	Date
0.1	First Release		2016.12.23
0.2	Added document number Notice on 2.8.3 Busbar Installation updated		2017.05.23
0.3	2.7 Rack Anchoring Stage edited		2018.01.11
0.4	2.8.5 Rear-to-Rear Installation added		2018.05.01

Approved By:		
Name	Signature	Date

Trusted Reviewers		
Name	Signature	Date

1.5 Acronyms and Abbreviations



The following acronyms and abbreviations are used in this manual.

Abbreviations	Full Name
AED	Automated External Defibrillator
BMS	Battery Management System
EHS	Environmental Health and Safety
ESS	Energy Storage System
LOTO	LOCK OUT/TAG OUT
OT	Overtemperature
OVP	Overvoltage Protection
PCS	Power Conversion System
SMPS	Switched Mode Power Supply
SOC	State Of Charge

Abbreviations	Full Name
SOH	State Of Health
SG	Switchgear
UT	Undertemperature
UVP	Undervoltage Protection
UPS	Uninterruptible Power Supply

2. Installing the Product

Because this product has a battery with more than 300V present when fully assembled, you must follow the general safety Instructions. This system must be installed by qualified, trained workers familiar with the required instruments. Use appropriate lifting methods when moving the batteries.

	WARNING
	<ul style="list-style-type: none">▪ The power terminal cap must be left in place on the power terminal of the tray for insulation.▪ Be sure to use insulated tools (torque wrench, extension, socket, etc.).▪ All the instruments must be insulated and no metal articles (e.g. watch, ring) should be present in the installation area.▪ All power switches must be turned off in advance.▪ Prepare a CO₂ fire extinguisher, a first aid kit, and an AED (automated external defibrillator) before installation.
	CAUTION <ul style="list-style-type: none">▪ If available, use a mechanical lift for lifting heavy (22 kg [50 lb.]) components. If there is no lift, two or three workers must move items weighing more than 22 kg (50 lb.).▪ The ambient temperature range must be 23°C ±5°C during installation.

2.1 Installation Procedure

This product must be installed by following the procedure below:



Figure 2-1: Installation Procedure

- **Preparation Stage**
 - Procedure
 - Unpacking
 - Ground Wire and Tools
 - Recommended Tools/Instruments
 - Appearance Inspection
- **Rack Anchoring Stage**
 - Transport the rack frame to the installation location after unpacking
 - Arrange the rack frame after checking the positions of holes in the frame and anchoring points
 - Perform the anchoring and ground connections
- **Rack Installation Stage**
 - Transport the battery modules to the installation location
 - Place the battery modules in the rack frame
 - Insert the Switchgear Assembly in the rack frame
 - Insert the SMPS Assembly in the rack frame
 - After all subassemblies are inserted in the rack frame, attach the subassemblies to the rack frame
 - Connect the busbars
 - Connect the signal cables from switchgear to module, and module to module
 - Connect the signal cables from switchgear to switchgear
- **System Installation Stage**
 - Connect the SMPS Assembly
 - Perform installation checks
 - Prepare the items for BMS configuration
 - Configure the BMS EEPROM settings

Estimated time for each step is listed in Table 2-1.

2. Installing the Product

Table 2-1: Estimated time for installation

No.	Step	Estimated Time (HH:MM)	Aggregated Time (HH:MM)
1	Unpacking	00:30	00:30
2	Inspection	01:00	01:30
3	Rack Anchoring	04:00	05:30
4	Rack Installation	Battery Module	05:50
		Switchgear Assembly	06:00
		SMPS Assembly	06:10
		Busbar	07:10
		Signal Cables	07:30
		Power and Control Cables	07:50
		Rack Fuse Installation	08:20
		AC Input Installation	08:40
		Cable Installation	08:50
BMS Configuration	09:00		

2.2 Preparation Stage—Procedure

For the preparation stage, perform the following steps:

1. Create the installation plan and check the equipment and instruments for installation.
2. Check the arrival schedule of the parts required.
3. Unpack the equipment.
4. Inspect the equipment.



WARNING

- Do not wear watches, rings, jewelry, or any other metal objects.
- Wear electrically insulated gloves and safety shoes.



CAUTION

- Store the product in a dust-free place with the moisture level of below 60% and the temperature level of 23°C ±5°C.
- Keep components out of direct sunlight.

2.3 Preparation Stage—Unpacking

Check the following parts during unpacking.

Table 2-2: Parts for 128S 3P Rack

No.	Items	Part No.	Amount (Unit: EA)	Remarks
1	RACK FRAME		3	
2	MODULE A Type		24	ELPM182-00001
3	MODULE B Type		24	ELPM182-00002
4	SWITCHGEAR		3	
5	SMPS ASSEMBLY (WITH SYSTEM BMS ASSEMBLY		3	For Rack #1, #2 and #3
6	SIDE COVER_HALF		2	
7	BUSBAR_BUSBAR M TO SG		6	Connect Module and SWITCH GEAR
8	BUS-BAR MAIN		42	High Current Connection for Modules
9	RACKFUSE BUSBAR_R_128S		3	Connect Module between #8 and #9
10	RACKFUSE BUSBAR_L_128S		3	Connect Module between #8 and #9
11	FUSE		3	Connect Module between #8 and #9
12	FUSE COVER		3	-
13	WIRE ASSY RACK TO MODULE SHIELDING		3	Connect Module and SWITCH GEAR
14	WIRE ASSY MODULE TO MODULE #1		42	Signal Connection for Modules
15	WIRE ASSY RACK TO RACK #2		2	Connect Rack between #1, #2 and #3
16	WIRE ASSY RACK TO RACK_2500		Optional	Rear to rear installation cable(2.5m)
17	WIRE ASSY RACK TO SYSTEM		1	Connect the Rack BMS CAN B to System BMS CAN A connector in the SMPS ASSEMBLY
18	WIRE ASSY RACK TO SMPS		6	DC IN Cable
19	WIRE ASSY MODULE TO MODULE #2		3	Signal Connect Module between #8 and #9
20	WIRE ASSY EARTH		6	
21	SCREW M5 X 10		38	Mounting SG, SMPS, WIRE ASSY EARTH and SIDE COVER_HALF to RACK FRAME
22	SCREW M8 X 16		96	Mounting BUSBAR to MODULE
23	SCREW M12 X 25		12	Mounting BUSBAR to SWITCH GEAR
24	SCREW M12 X 16		6	Mounting BUSBAR to FUSE
25	SCREW M10 X 25		8	Mounting Rack Frame to Rack Frame
26	NUT M10		8	Mounting Rack Frame to Rack Frame
27	M10 FLAT WASHER		8	Mounting Rack Frame to Rack Frame

2.4 Preparation Stage—Ground Wire and Tools

Ground wires for the racks must be provided by the installer. Customer-supplied ground wires must adhere to the specifications below.

2.4.1 Ground Wires

Use ground wire that is 70 sq mm. The ground wire specifications are:

Table 2-3: Ground Wire Specification¹

Wire No.	Terminal Type
70sq or more thick one	M12 2 Hole Ring Terminal

2.4.2 Ground Wire Fasteners

Specifications for the ground wire fastening screws are:

Table 2-4: Ground Wire Fastener Specification²

Size	Hardness	Thread Pitch	Material
M12-30L	70 (Rockwell)	1.25 mm (0.05 in)	SS304

2.4.3 Rack Fasteners (Anchors)

Specifications for the rack fastener screws for anchoring the rack frame to the floor are:

Table 2-5: Rack Fastener Specification³

Size	Hardness	Thread Pitch	Material
M16-L (BOTTOM Anchor)	70 (Rockwell)	2.0 mm (0.08 in)	SS304

2.4.4 Multiple Rack Fasteners

Specifications for the rack fastener screws for installing multiple rack frames side-by-side are:

Table 2-6: Rack Fastener Specification (Side / Rear)

Size	Hardness	Thread Pitch	Material
M10-30L (Side)	70 (Rockwell)	1.5 mm (0.06 in)	SS304

¹ Not provided. Must be procured by the installer or customer







² Not provided. Must be procured by the installer or customer

³ Not provided. Must be procured by the installer or customer

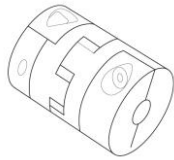
2.5 Preparation Stage—Recommended Tools/Instruments

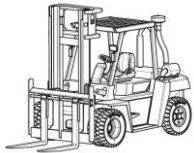
Installers must provide these tools for installing the battery:

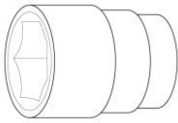
Table 2-7: Recommended Tools and Instruments

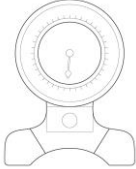
No.	Items	Usage	Appearance
1	Power Screwdriver/Drill (Max torque: 26Nm/270 kgf/cm)	To fasten switchgear and SMPS assemblies to the rack frames (5.1–6.1Nm/50–60 kgf/cm)	
2	Torque Limiter	For use with torque wrench	
3	Phillips Screwdriver or Bit	To fasten switchgear and SMPS assemblies to the rack frames (M5 Tip)	
4	Box Cutter	Opening boxes	
5	Forklift	Moving rack frames and pallets containing modules and switchgear	
6	Insulated Torque Wrench	Installing a high-current cable (10~50 N.m / 100 ~ 500 kgf.cm)	
7	Insulated Sockets (13 mm, 17mm and 19mm)	Installing power cables and busbars	
8	Insulated Extension for Socket	Installing a power cable	
9	Inclinometer/Level	Installing a rack frame	

No.	Items	Usage	Appearance
10	Battery Tester	Measure battery module's voltage and internal impedance	

2.6 Preparation Stage—Visual Inspection

During visual inspection, the inspector should check for:

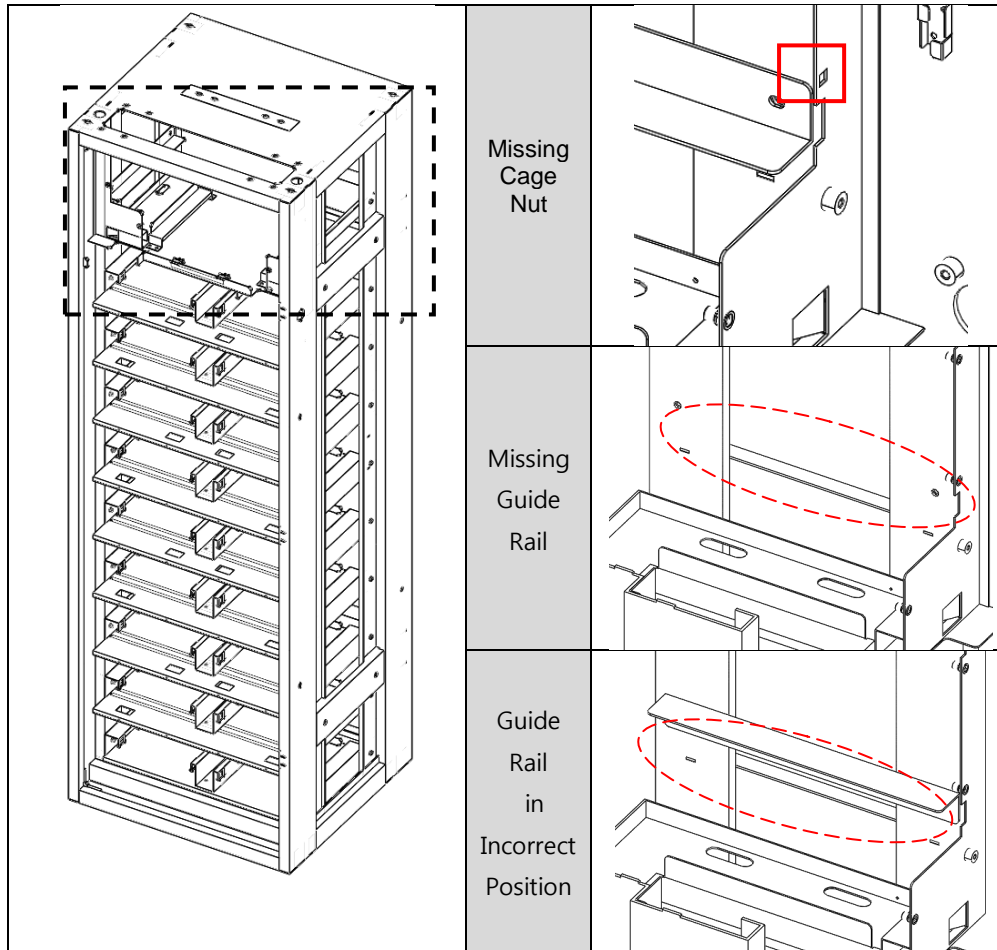

Figure 2-2: Faulty Cases



CAUTION

- If any defects are found during the inspection, contact the SAMSUNG SDI customer service department.

2.6.1 Inspecting the Rack Frame

After transporting the rack frame to the installation location, check for:

- Structural damage
- Paint peeling
- Damaged or protruding screws.

After completion, install or package the rack for protection during storage.

2.6.2 Visual Inspection of the Modules

After transporting the modules to the installation location, check for:

- Physical damage to the exterior
- Damaged or protruding screws
- Proper voltage and internal impedance of the battery modules using the battery tester.

Table 2-8: Module Voltage and Internal Impedance

No.	Items	Value
1	Voltage Check	28.712 ~ 29.104V
2	Internal Impedance Check	3.0 ~ 4.3 mΩ

After completion, install the battery module in the previously installed rack or return the battery module to its original packing for protection during storage.

2.6.3 Inspecting the Switchgear

After transporting the Switchgear to its installation location, check for:

- Physical damage
- Paint peeling
- Damaged or protruding screws.

After completion, install the switchgear in the previously installed rack or return the switchgear to its original packing for protection during storage.

2.6.4 Inspecting the SMPS assembly

After transporting the SMPS Assembly to its installation location, check for:

- Physical damage
- Paint peeling
- Damaged or protruding screws.

After completion, install the SMPS in the previously installed rack or return the SMPS to its original packing for protection during storage.

2.7 Rack Anchoring Stage

Install the rack frame on a flat, level surface.

► **To attach the rack and perform the related works**

	CAUTION
	<ul style="list-style-type: none"> ▪ Use a proper transportation method considering the weight of the rack frame. ▪ Ensure that the safety of the working place is maintained. ▪ When using a forklift, lift the rack frame from the front. ▪ When a forklift cannot be used, use a mechanical lift or move it by hand with three or more people. ▪ Use lock washers to prevent bolts from loosening. ▪ Use an inclinometer or carpenter's level to ensure that the rack frame is plumb.

	NOTICE
	<ul style="list-style-type: none"> ▪ Failure to anchor the rack frame on a flat and level surface may distort the rack frame after installing the racks side-by-side. ▪ Frame distortion may make the rack doors difficult or impossible to open.

In order to anchor the racks in all four points, racks are recommended to be placed according to the clearance distances listed in the figures below. In seismically active areas, all four anchor points of the rack must be installed.

To reduce the product footprint, the racks can be installed side-by-side and rear-to-rear against a wall or next to another rack. In this case, only two anchor points on the front side of each rack can be installed. Proper cooling and ventilation of the installed area is recommended for racks installed with no side and rear clearance. Front side of the rack must be cleared for installation, maintenance, service access, and ventilation and cooling.

Clearance from the top of the rack frame is not required and the top of the rack frame can be covered to prevent any foreign objects from falling into the battery rack frame.

Table 2-9: Rack Clearance Distances

Configuration	Anchor points per rack	Clearance Distance (mm)			
		Side (end)	Side (adjacent)	Rear	Front
Single Rack	2 (Front) not rated for seismic event	0	n/a	0	1000
	4 (All) – Telcordia Zone 3	workable	n/a	workable	1000
Multiple Racks (Side-to-Side)	2 (Front) not rated for seismic event	0	0	0	1000
	4 (All) – Telcordia Zone 3	workable	0	workable	1000
Multiple Racks (Side-to-Side and Rear-to-Rear)	2 (Front) not rated for seismic event	0	0	0	1000
	4 (All) – Telcordia Zone 3	workable	0	workable	1000

Two anchor points (not rated for seismic event)

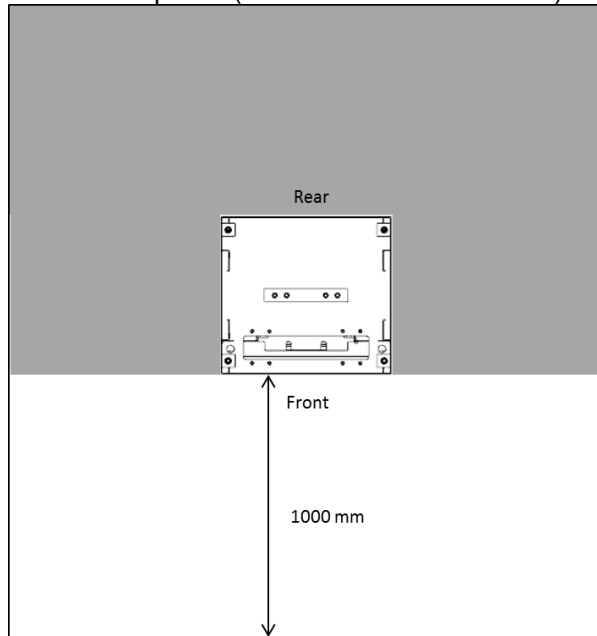

Four anchor points (Telcordia Zone 3)

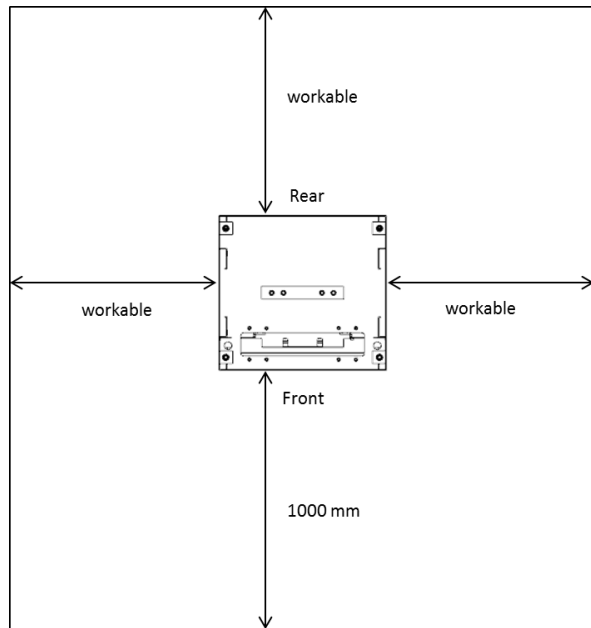
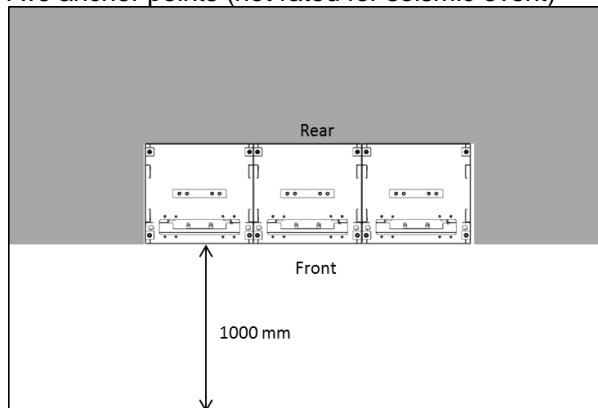

Figure 2-3: Clearance Distance for Single Rack Frame

Two anchor points (not rated for seismic event)



Four anchor points (Telcordia Zone 3)

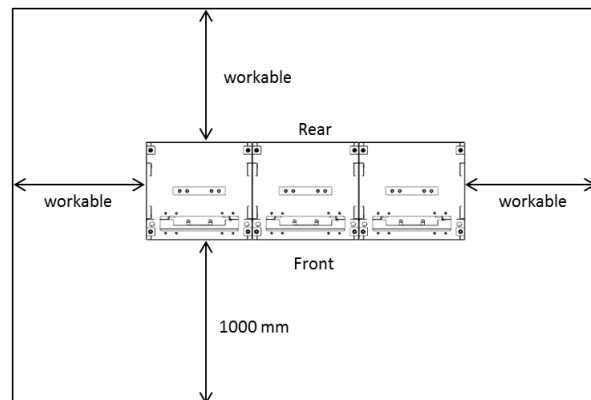

Figure 2-4: Clearance Distance for Multiple Rack Frames

2. Installing the Product

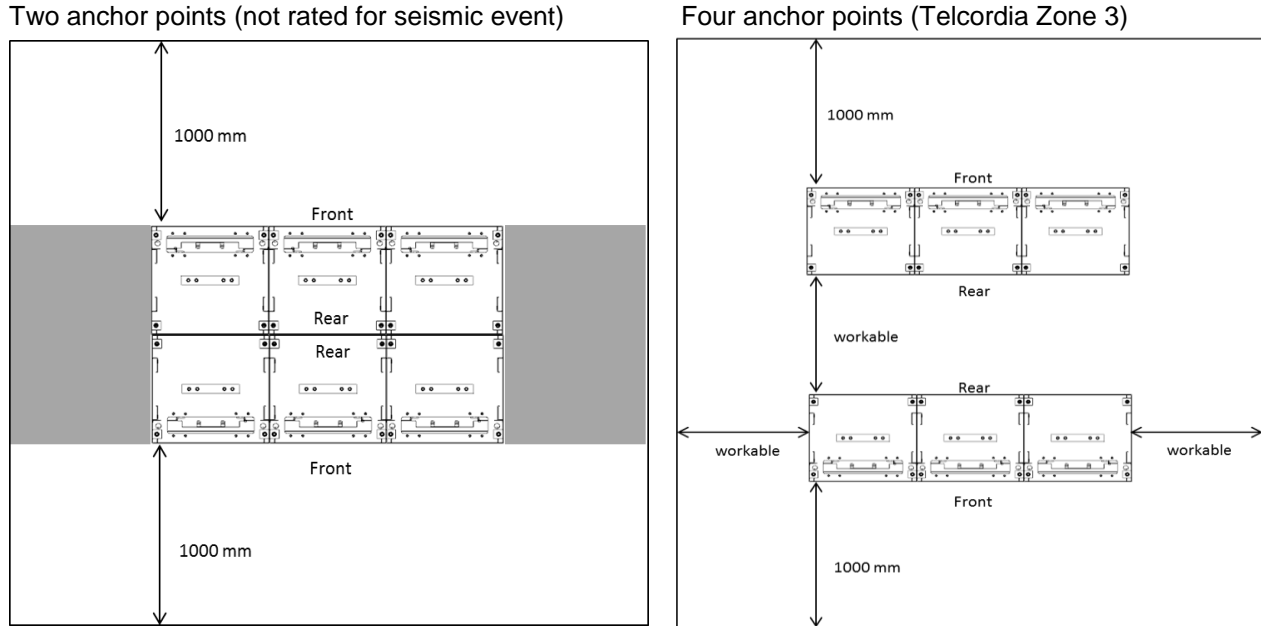

Figure 2-5: Clearance Distance for Multiple Rack Frames Installed Rear-to-Rear

1. After unpacking the rack frame, transport it to its installation location.
2. Arrange the rack frame after verifying that the holes in the frame and anchoring points are aligned.
3. Remove the side panels and rear panel from the rack frame.
4. Connect four anchoring points on the bottom of the rack.

	NOTICE
	<ul style="list-style-type: none"> ▪ Anchor the frame with M16 bolts and nuts. ▪ The fastening torque should be 140Nm / 1,425kgf cm. ▪ Check the rack and other parts for distortion caused by unpacking.

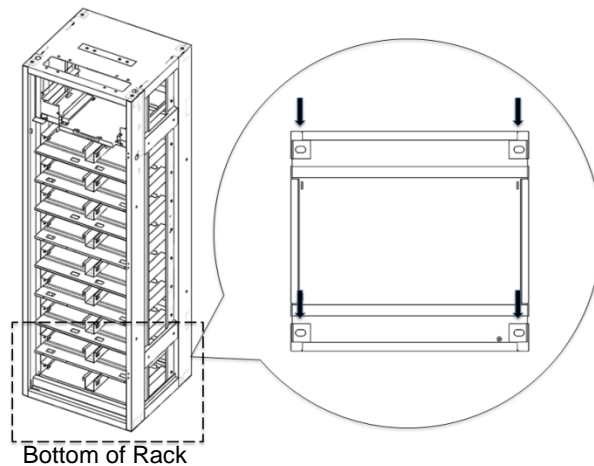

Figure 2-6: Rack Anchoring Points (4 EA)

5. Connect the racks, using M10 hardware through holes in the sides (“SCREW M10 X 25,” “M10 FLAT WASHER” and “NUT M10”). Torque the bolts to 30Nm (300kgf cm)..

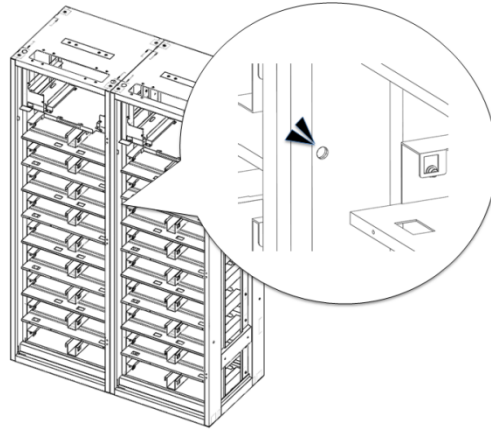

Figure 2-7: Holes on the sides of the rack

6. Anchor the rack horizontally by using an inclinometer/level.
7. After all the rack frames are anchored, assemble the side covers “SIDE COVER_HALF” of the outermost rack frames. M5 Screws “SCREW M5 X 10” are used to assemble the side covers. Four screws are needed for each side cover. Fasten the screws using torque of 5.1–6.1 N·m (50–60 kgf·cm).

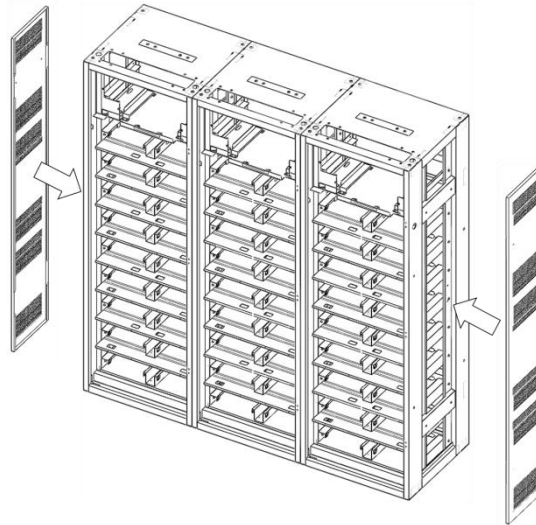

Figure 2-8: Assembling Side Covers

2. Installing the Product

8. Assemble the rear covers to the rack frames. M5 Screws “SCREW M5 X 10” are used to assemble the rear covers. Four screws are needed for each rear cover. Fasten the screws using torque of 5.1–6.1 N·m (50–60 kgf·cm).

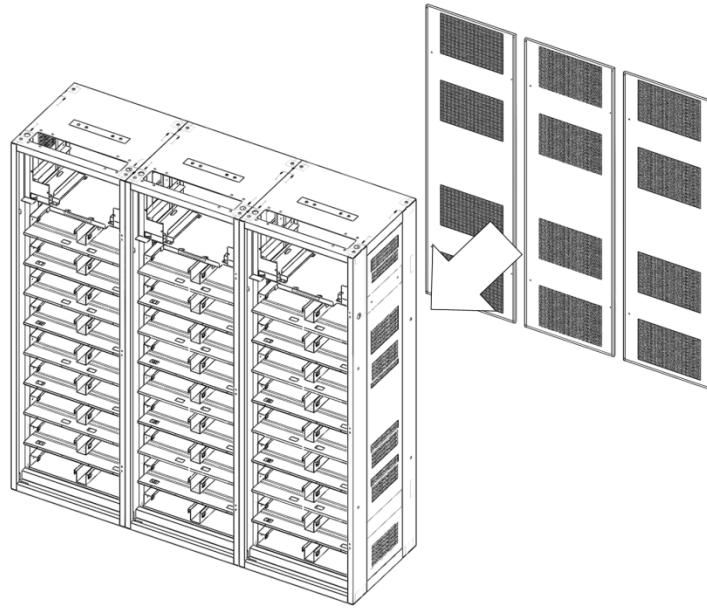







Figure 2-9: Assembling Rear Covers

2.8 Rack Installation Stage

	<p>WARNING</p> <p>Arc Flash and Shock Hazard Insulated tools are required for any work on this energized equipment.</p>
	<p>WARNING</p> <p>Sharp Edges Wear gloves and other protective gear to prevent injury.</p>
	<p>WARNING</p> <p>Pinch Point Use caution when working in the enclosure to prevent injury.</p>
	<p>CAUTION</p> <p>Heavy Object Can cause muscle strain or back injury. Use lifting aids and proper lifting techniques when moving trays, batteries and other heavy objects.</p>

2.8.1 Battery Module Installation

1. Transport battery modules to the installation location.
2. Measure the modules' voltage and internal impedance. All modules in one rack frame must be near the same state of charge. The batteries must have an output within 300mV of each other and internal impedance difference of 1.3mΩ. Refer to Table 2-8: Module Voltage and Internal Impedance.
3. Place the battery modules on the rack frame.

	<p>Important</p> <ul style="list-style-type: none"> ▪ Samsung recommends installing Battery Modules in the upper shelves first and proceeding to the bottom. (Two Type B battery modules are inserted in the ninth shelf from the bottom.) ▪ Sixteen battery modules can be inserted into a rack frame as shown in Figure 2-12.
---	--

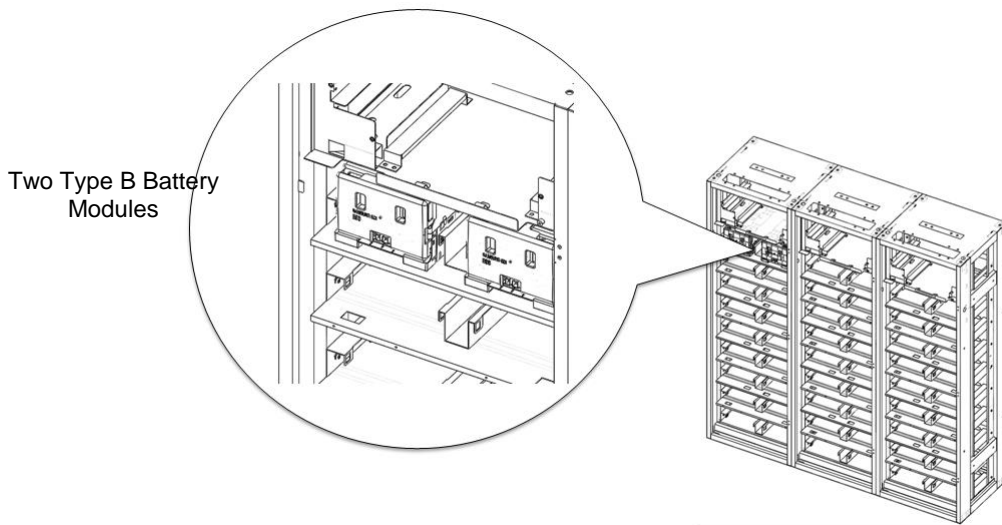

Figure 2-10: Insertion of Modules on the Ninth Shelf from the Bottom

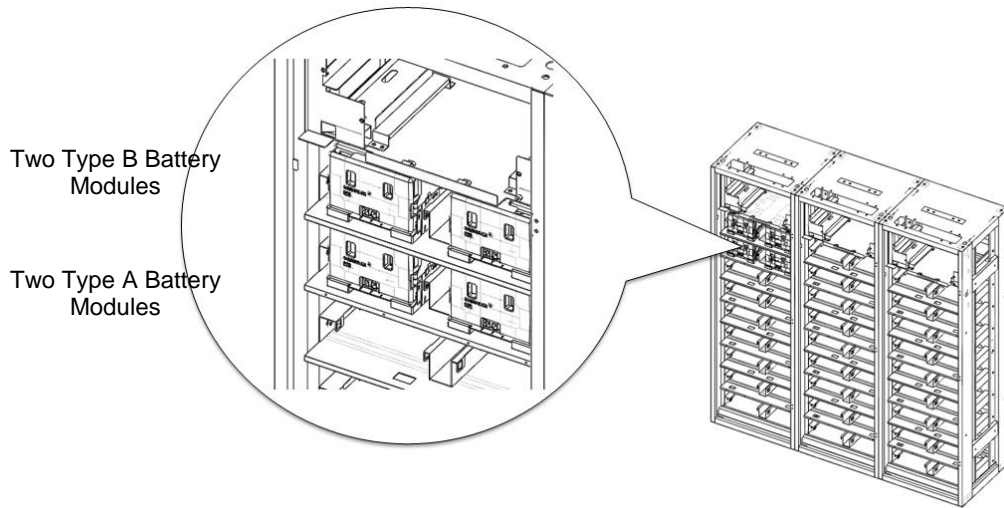

Figure 2-11: Battery Module Arrangement on Eighth and Ninth Shelves

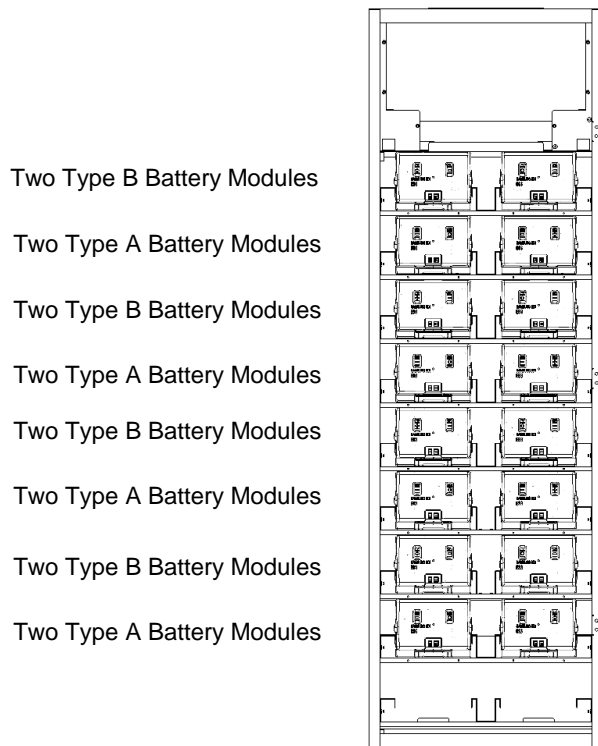

Figure 2-12: Battery Module Arrangement

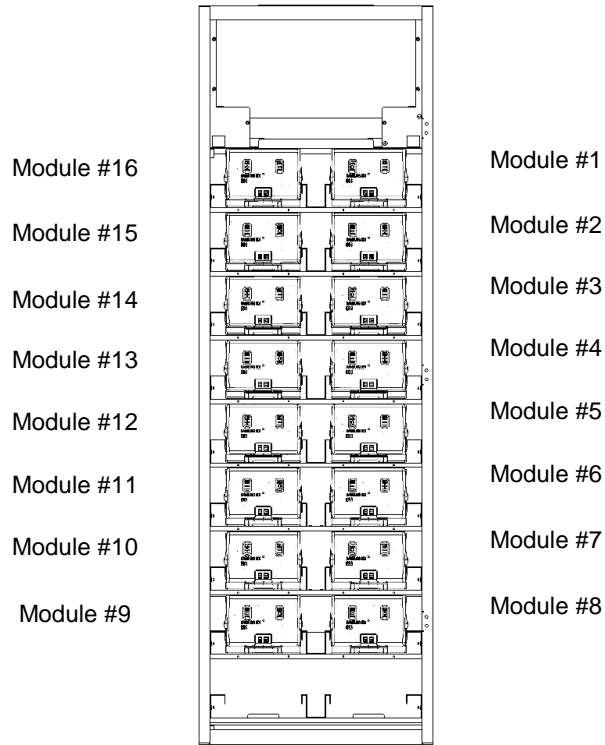

Figure 2-13 : Module Number



Important

- Samsung recommends installing modules from top to bottom.
- The last slot is empty as seen in Figure 2-14.

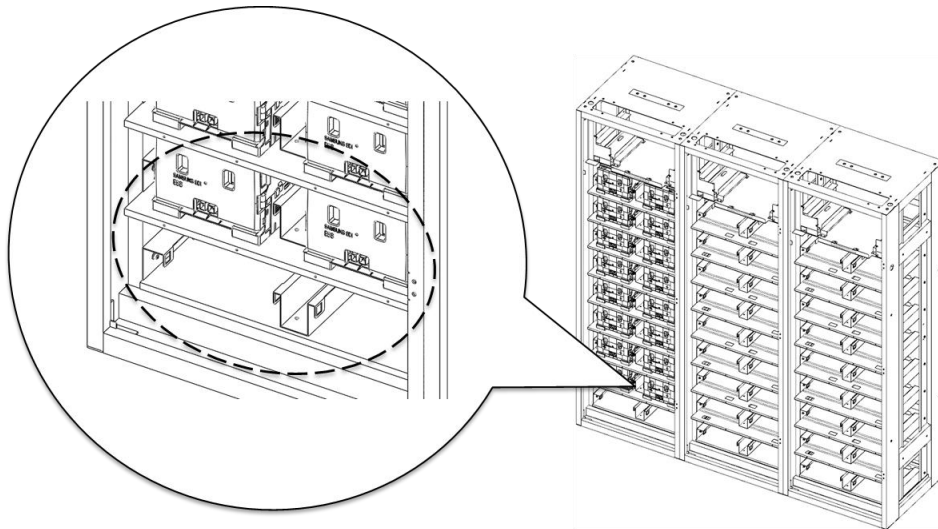



Figure 2-14: Insertion of modules on 1st shelf

2.8.2 Switchgear and SMPS Assembly Installation

	Important
	<ul style="list-style-type: none"> ▪ Attach each Switchgear to its rack frame with four M5 x 10L screws. (Torque: 5.1–6.1 Nm [50–60 kgf cm]) ▪ Verify that the torque setting is correct.

1. Insert the Switchgear Assembly through the front of the rack as shown in Figure 2-15: Inserting Switchgear

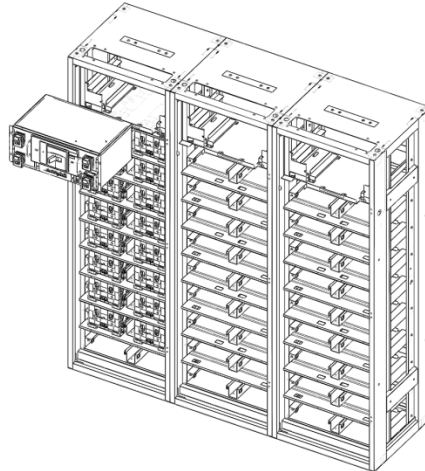

Figure 2-15: Inserting Switchgear

2. After all Switchgear Assemblies are inserted in the rack frames, attach each to the rack frame with four M5 x 10L bolts. (Torque: 5.1–6.1 Nm [50–60 kgf cm])

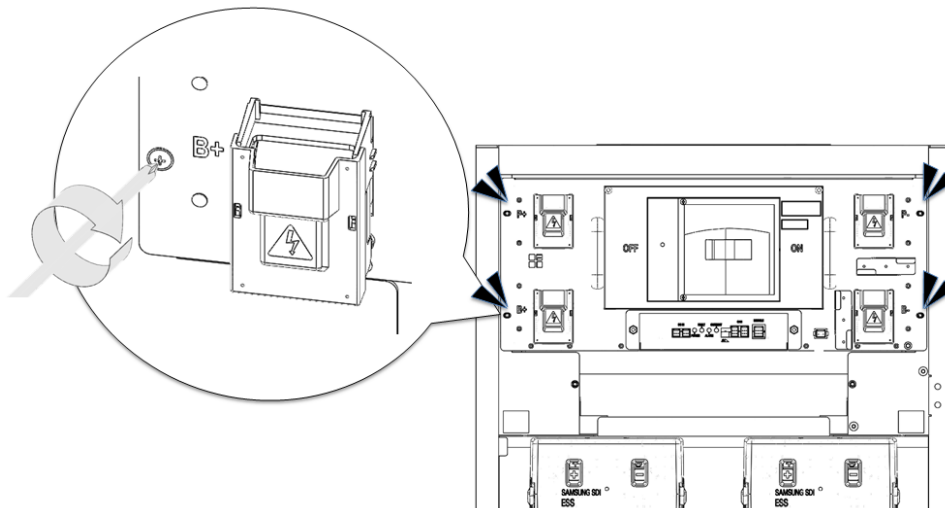

Figure 2-16: Attaching a Switchgear Assembly to a Rack Frame

3. After all Switchgear Assemblies are inserted into the rack frame, connect the ground cable.

2. Installing the Product



NOTICE

Connect a ground cable between the Switchgear Assembly and the Rack Frame (SCREW M5 x 10L). (Torque: 5.1–6.1 Nm [50–60 kgf-cm])

- Verify that the torque setting is correct.

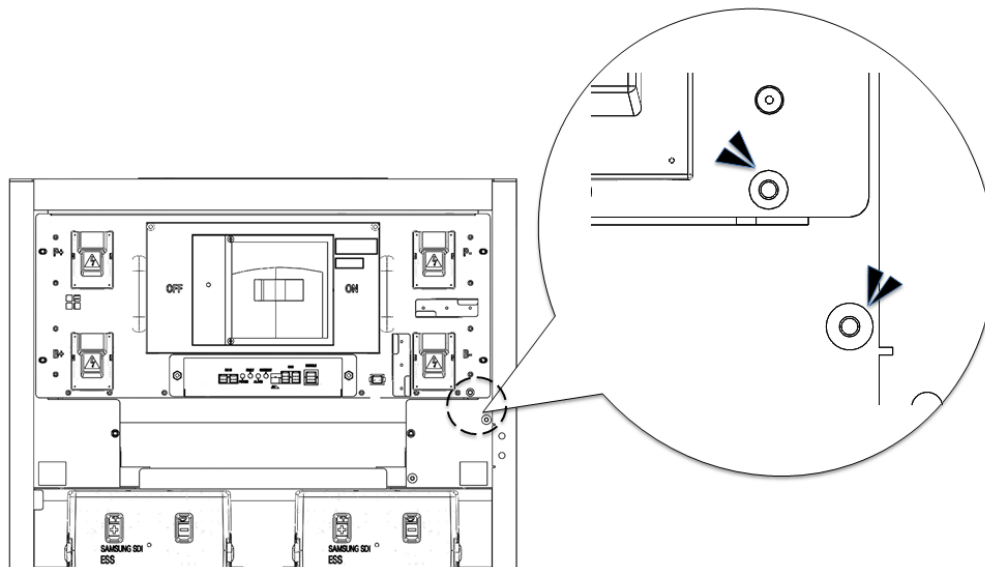



Figure 2-17: Ground Cable Connection to the Switchgear Assembly

4. Insert SMPS Assembly into the rack frames designated for SMPS Assembly as shown in Figure 2-18: Inserting SMPS Assembly

	Important <ul style="list-style-type: none">▪ Attach the inserted SMPS Assemblies to the rack frames by fastening each with four M5 x 10L screws▪ (Torque: 5.1–6.1 Nm [50–60 kgf cm])▪ Verify that the torque setting is correct.
---	--

5. Slide the SMPS Assembly into the rack frame on the shelf designated for the Switchgear Assembly as shown below.

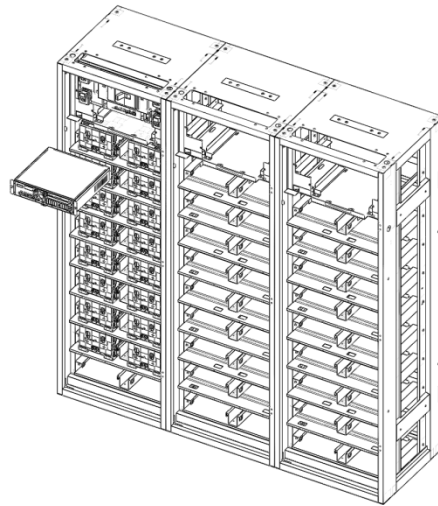

Figure 2-18: Inserting SMPS Assembly

6. After all SMPS Assemblies are inserted into the rack frames, attach them to the Switchgear with screws (Torque: 5.1–6.1 Nm [50–60 kgf cm])

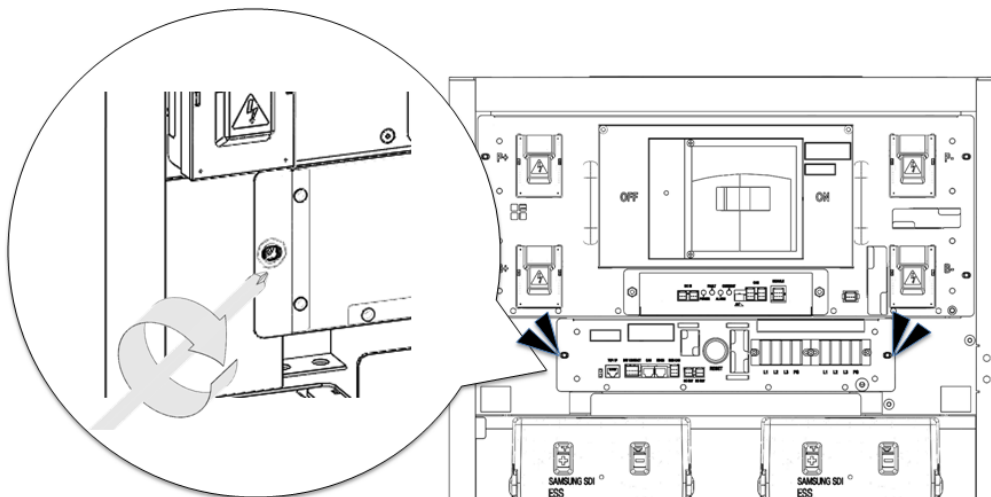



Figure 2-19: Attaching the SMPS Assembly

2. Installing the Product

7. After all SMPS Assemblies are attached to the rack frames, connect the ground cables.

	NOTICE
	<ul style="list-style-type: none"> ▪ Connect a ground cable between the SMPS Assembly and the Rack Frame with an M5 x 10L screw. (Torque: 5.1–6.1 Nm [50–60 kgf cm]) ▪ Verify that the torque setting is correct.

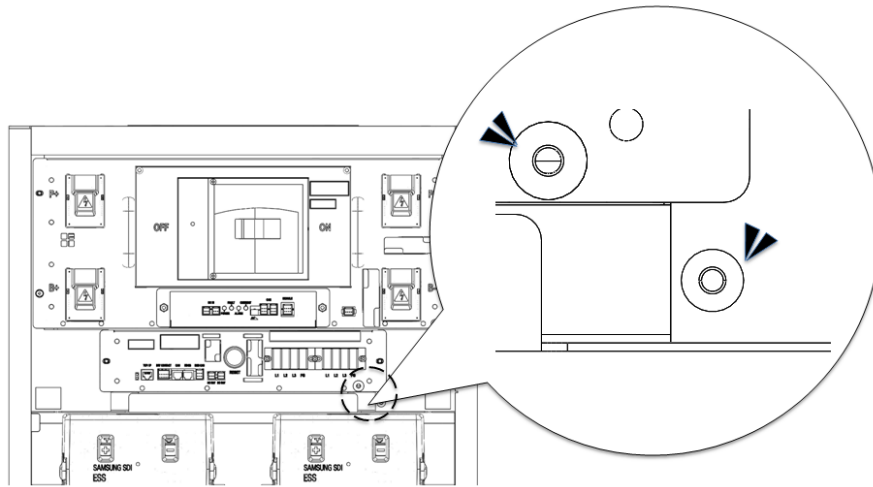

Figure 2-20: Ground cable connection to the SMPS Assembly

2.8.3 Busbar Installation

Connect the power busbars between modules



Verify with a voltmeter that no power is present on the system. Use lock out/tag out procedures to secure the UPS and batteries.

CAUTION	
	<ul style="list-style-type: none"> ▪ Please follow the instructions to protect the module BMS against damage. ▪ Important: DO NOT deviate from the sequence of steps below. ▪ The system's voltage will increase proportionally as battery modules are connected. Exercise extreme caution prevent the terminals from contacting anything except their intended mounting points. ▪ Terminals and their connected wires have either positive or negative polarity (Positive: B+, P+; Negative: B-, P-). The polarity of a terminal or a wire connected to the terminal is on the front of each module and switchgear. Exercise extreme caution to prevent the terminals and/or wires with opposite polarity from contacting with each other. ▪ It is recommended not to touch the battery positive(+) or negative(-) terminal for the batteries with rack frame. There is no evidence of dielectric breakdown because of electrical isolation between the battery positive (+) or negative (-) terminals and rack frame. However, it is recommended not to touch them for safety because It is possible to touch between battery positive (+) and negative (-) through the rack frame.

NOTICE	
	<ul style="list-style-type: none"> ▪ Connect the power busbar with an M8 screw for battery module terminals ▪ When tightening the screws, make sure they are at a straight angle from the battery module terminals to avoid damage to the nuts inside. ▪ First, assemble the screws using a Phillips-head tip screwdriver using fastening torque of less than 5.1 Nm (50 kgf/cm). ▪ Then, use an insulated torque wrench extension with a 13 mm socket. Use fastening torque of 8.16–11.94 Nm (80–117 kgf/cm).

NOTICE	
	<ul style="list-style-type: none"> ▪ Connect the power bus-bar with an M12 screw for switchgear terminals ▪ When tightening the screws, make sure they are at a straight angle from the switchgear terminals to avoid damage to the nuts inside. ▪ The fastening torque should be 30 Nm (300 kgf-cm) ▪ Use an insulated torque wrench extension with a 19 mm socket.

Important	
	<ul style="list-style-type: none"> ▪ The power terminals, such as "B+," "B-," "P+," and "P-," of the module and Switchgear are covered with the power terminal cover to guard against a short circuit. ▪ At each step in this process, you must remove the cover prior to connecting a power busbar and reattach the cover immediately after connecting the power busbars.

2. Installing the Product

1. Remove all battery module front covers and switchgear B+, B- covers.

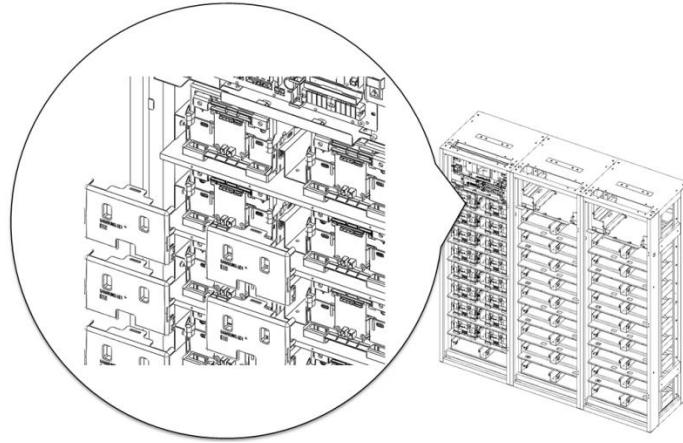

Figure 2-21: Removing the Front Covers

2. Connect Switchgear B- and Module #1 B- using “BUSBAR_BUSBAR M TO SG”. Switchgear B- terminal is connected using M12 screw and Module #1 B- terminal is connected using M8 screw.

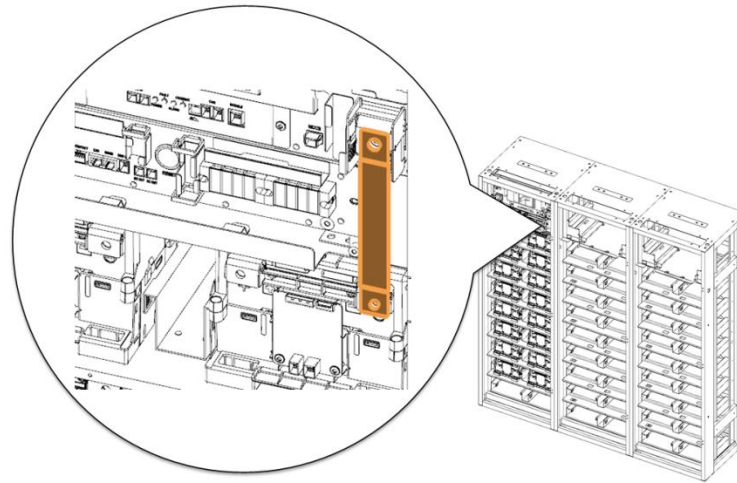

Figure 2-22: Connect Switchgear B- and Module #1 B-

3. Connect Module #1 B+ and Module #2 B- using "BUS-BAR MAIN". Connect using M8 screw.

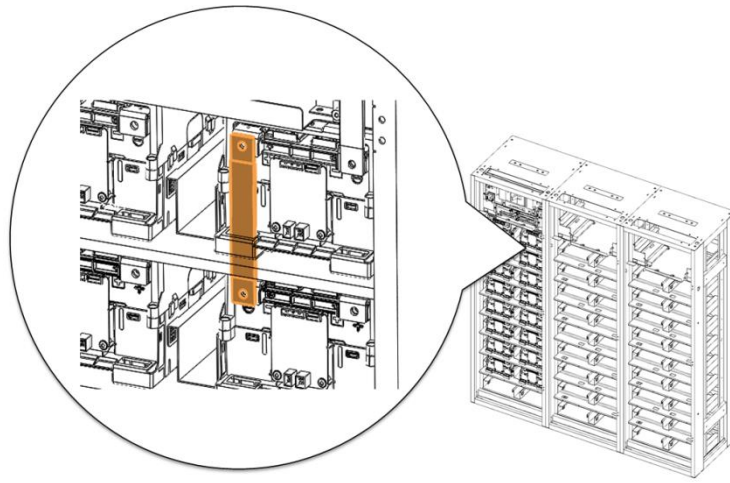

Figure 2-23: Connect Module #1 B+ and Module #2 B-.

4. Connect Module #2 B+ and Module #3 B- using "BUS-BAR MAIN". Connect using M8 screw.

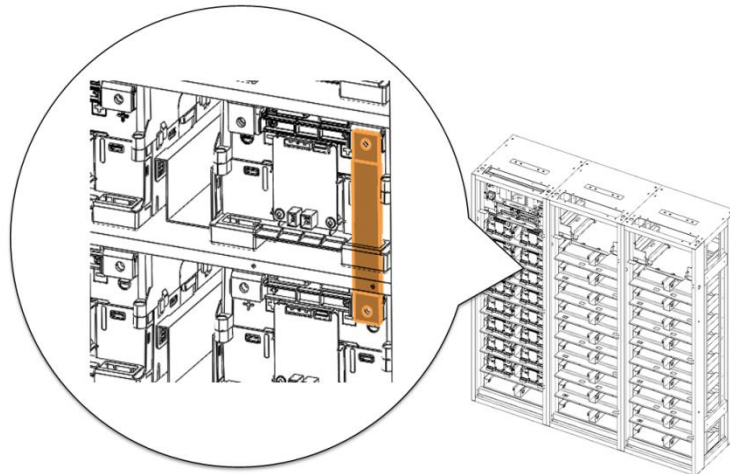

Figure 2-24: Connect Module #2 B+ and Module #3 B-.

2. Installing the Product

5. Connect Module #3 B+ and Module #4 B- using "BUS-BAR MAIN". Connect using M8 screw.

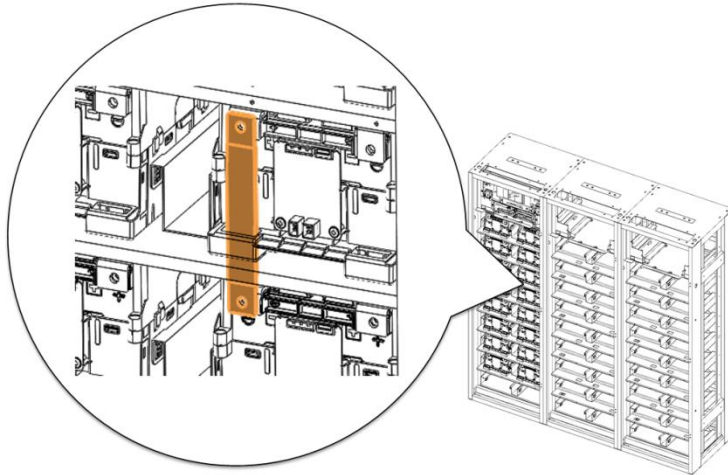

Figure 2-25: Connect Module #3 B+ and Module #4 B-.

6. Connect Module #4 B+ and Module #5 B- using "BUS-BAR MAIN". Connect using M8 screw.

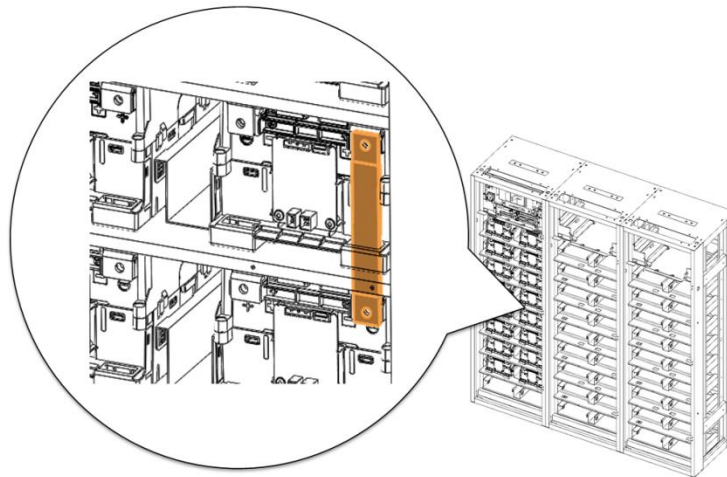

Figure 2-26: Connect Module #4 B+ and Module #5 B-.

7. Connect Module #5 B+ and Module #6 B- using "BUS-BAR MAIN". Connect using M8 screw.

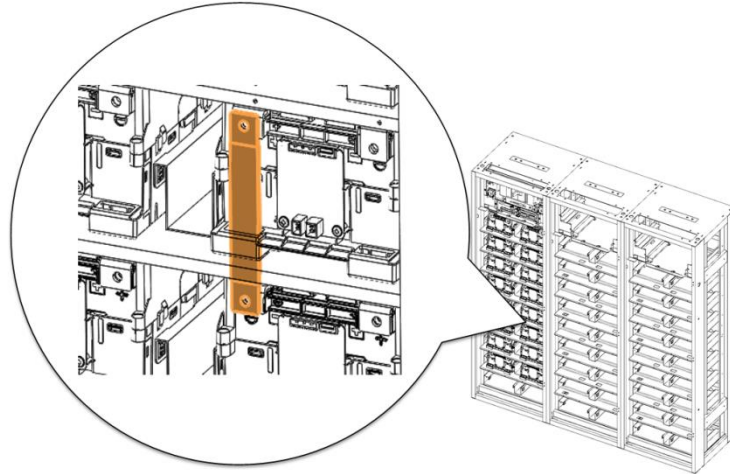

Figure 2-27: Connect Module #5 B+ and Module #6 B-.

8. Connect Module #6 B+ and Module #7 B- using "BUS-BAR MAIN". Connect using M8 screw.

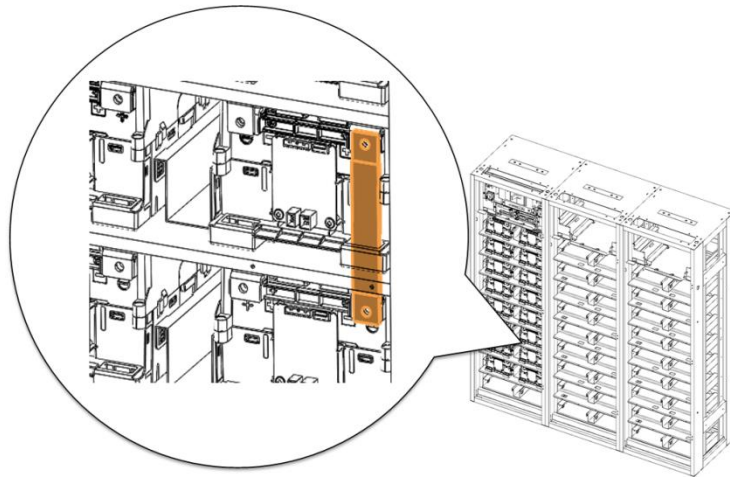

Figure 2-28: Connect Module #6 B+ and Module #7 B-

9. Connect Module #7 B+ and Module #8 B- using "BUS-BAR MAIN". Connect using M8 screw.

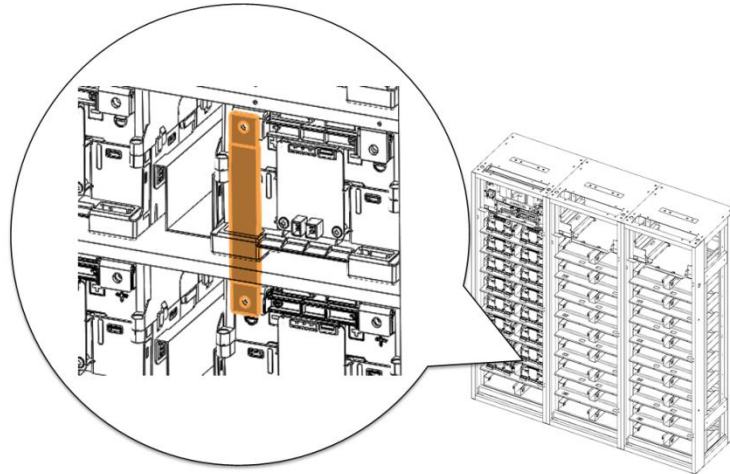

Figure 2-29: Connect Module #7 B+ and Module #8 B-

10. Connect Module #9 B+ and Module #10 B- using "BUS-BAR MAIN". Connect using M8 screw.

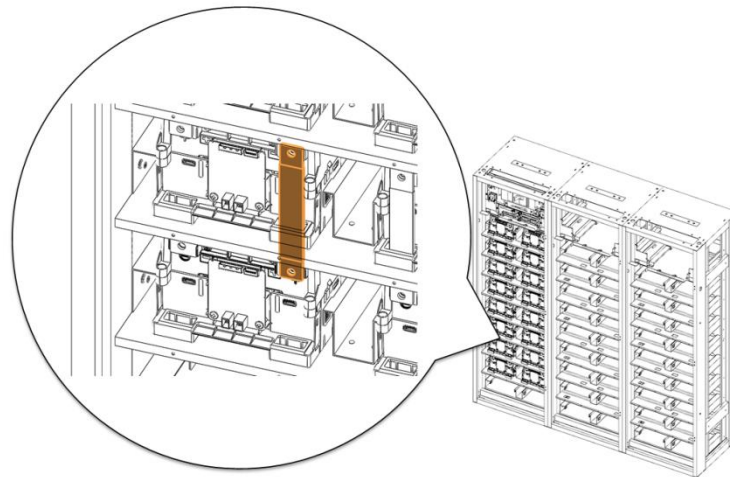

Figure 2-30: Connect Module #9 B+ and Module #10 B-

11. Connect Module #10 B+ and Module #11 B- using "BUS-BAR MAIN". Connect using M8 screw.

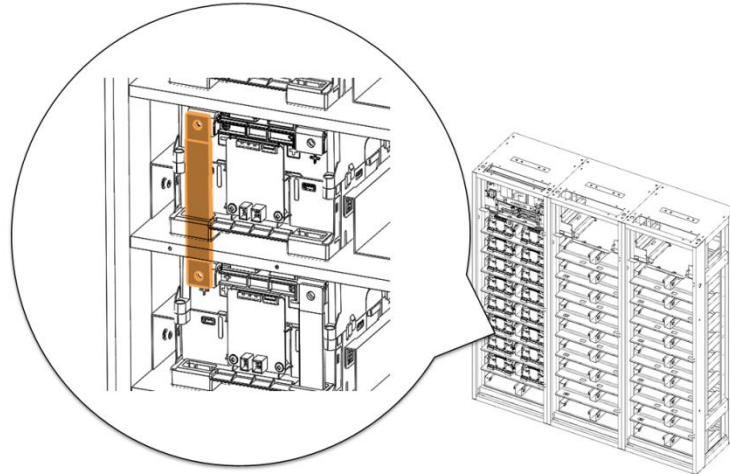

Figure 2-31: Connect Module #10 B+ and Module #11 B-.

12. Connect Module #11 B+ and Module #12 B- using "BUS-BAR MAIN". Connect using M8 screw.

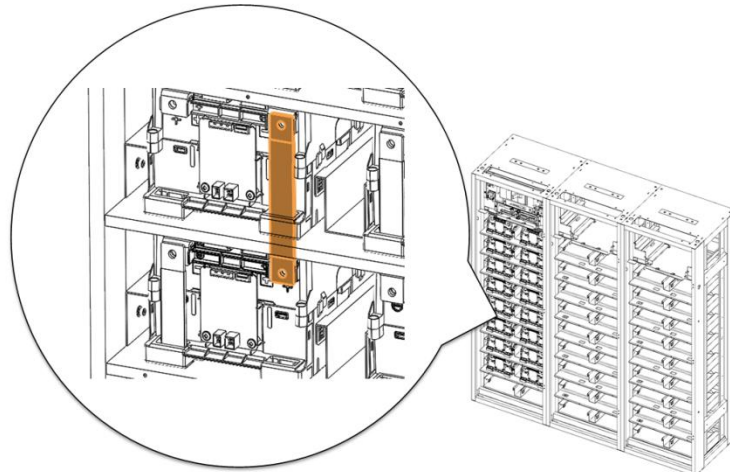

Figure 2-32: Connect Module #11 B+ and Module #12 B-.

13. Connect Module #12 B+ and Module #13 B- using "BUS-BAR MAIN". Connect using M8 screw.

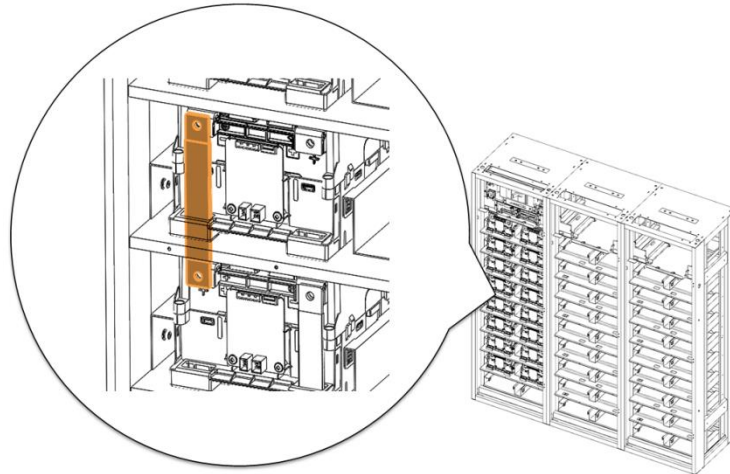

Figure 2-33: Connect Module #12 B+ and Module #13 B-.

14. Connect Module #13 B+ and Module #14 B- using "BUS-BAR MAIN". Connect using M8 screw.

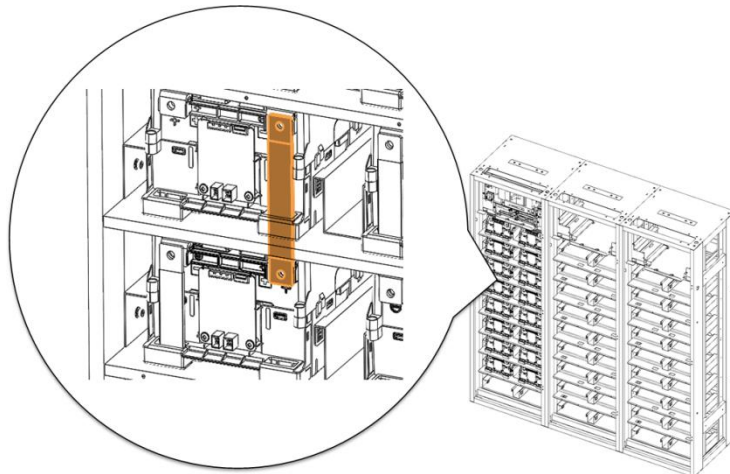

Figure 2-34: Connect Module #13 B+ and Module #14 B-.

15. Connect Module #14 B+ and Module #15 B- using "BUS-BAR MAIN". Connect using M8 screw.

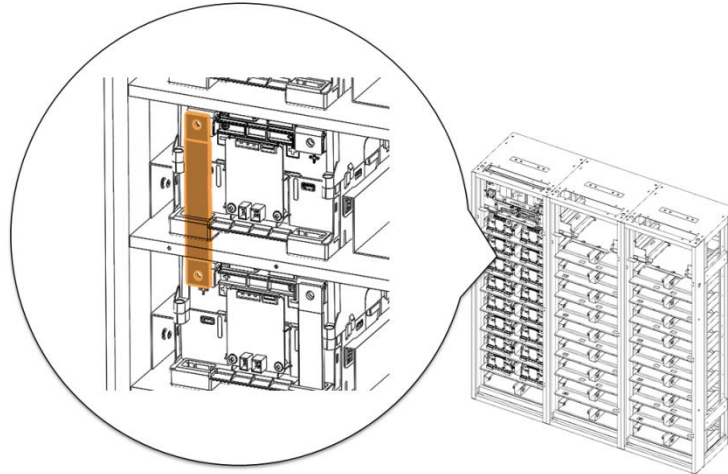

Figure 2-35: Connect Module #14 B+ and Module #15 B-.

16. Connect Module #15 B+ and Module #16 B- using "BUS-BAR MAIN". Connect using M8 screw.

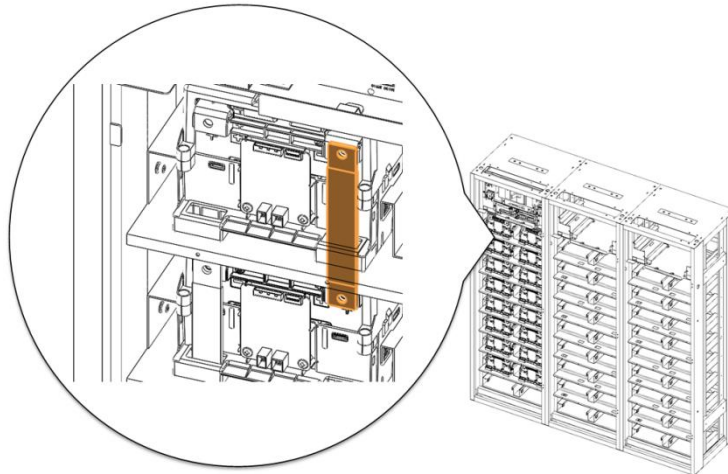

Figure 2-36: Connect Module #15 B+ and Module #16 B-.

2. Installing the Product

17. Connect Switchgear B+ and Module #16 B+ using “BUSBAR_BUSBAR M TO SG”. Switchgear B+ terminal is connected using M12 screw and Module #16 B+ terminal is connected using M8 screw.

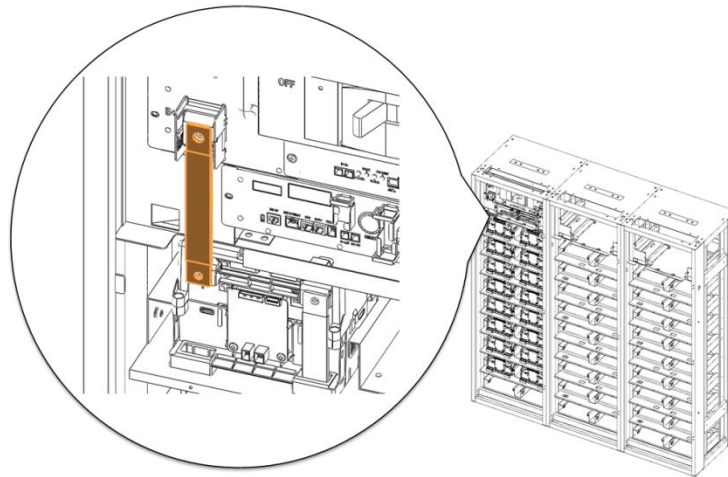

Figure 2-37: Connect Switchgear B+ and Module #16 B+

18. Reassemble the Front Cover of Modules and Switchgear B+, B- terminals.

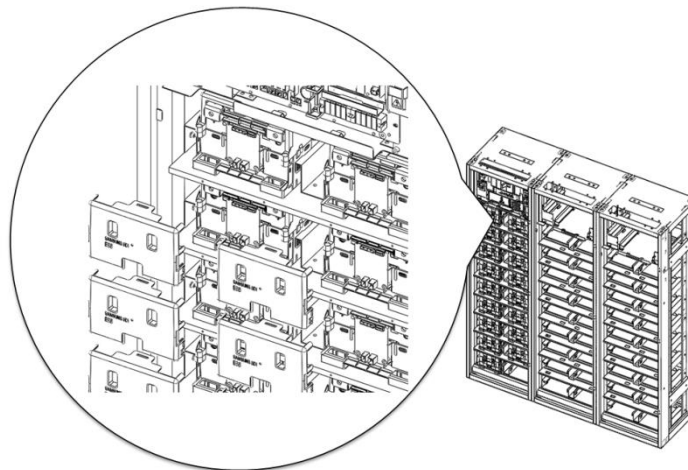

Figure 2-38: Reassemble the Front Cover.

2.8.4 Module and Switchgear Signal Cable Connection

Connect the signal cables for Switchgear and Module BMS's for each Module.



NOTICE

- Please use the proper signal cables as specified by the part numbers below.



WARNING

Rack BMS / Module BMS Damage

Do not insert both ends of the signal cable WIRE ASSY MODULE TO MODULE #1 or WIRE ASSY MODULE TO MODULE #2 into the same Battery Module.

1. Connect the signal cable "WIRE ASSY RACK TO MODULE SHIELDING" between the switchgear "MODULE" connector and Module #1 "OUT" connector. Pass the cable through the opening above Module #1.

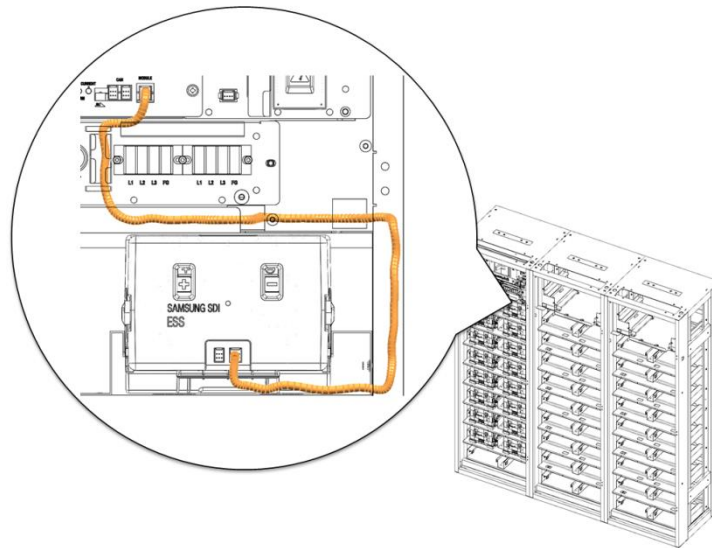

Figure 2-39: Rack BMS to Module #1 OUT Signal Cable

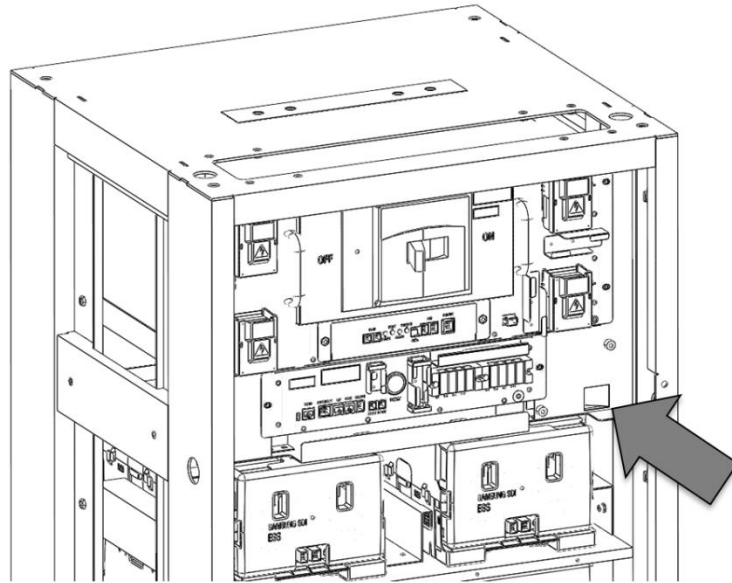

Figure 2-40: Opening for Cable Installation

2. Connect the signal cable "WIRE ASSY MODULE TO MODULE #1" from Module #1 "IN" to Module #2 "OUT".

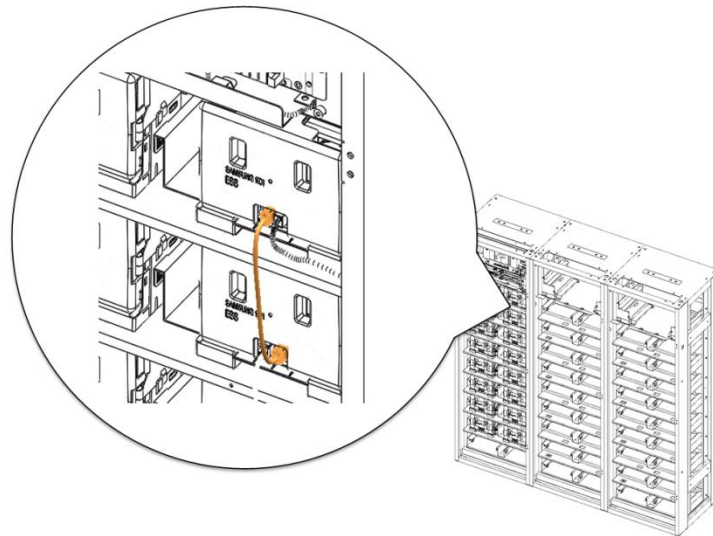

Figure 2-41: Module #1 to Module #2 Signal Cabling

3. Connect the signal cable "WIRE ASSY MODULE TO MODULE #1" from Module #2 "IN" to Module #3 "OUT".

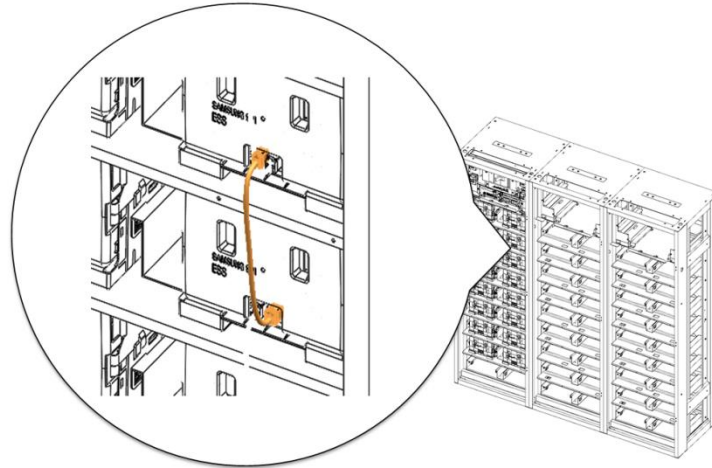

Figure 2-42: Module #2 to Module #3 Signal Cabling

4. Connect the signal cable "WIRE ASSY MODULE TO MODULE #1" from Module #3 "IN" to Module #4 "OUT".

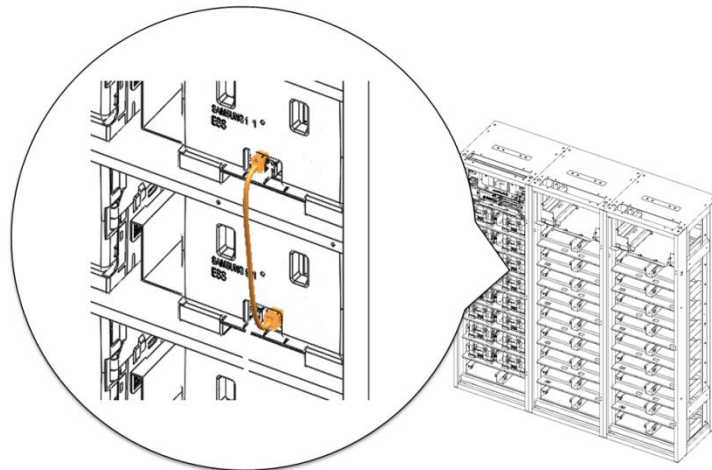

Figure 2-43: Module #3 to Module #4 Signal Cabling

5. Connect the signal cable "WIRE ASSY MODULE TO MODULE #1" from Module #4 "IN" to Module #5 "OUT".

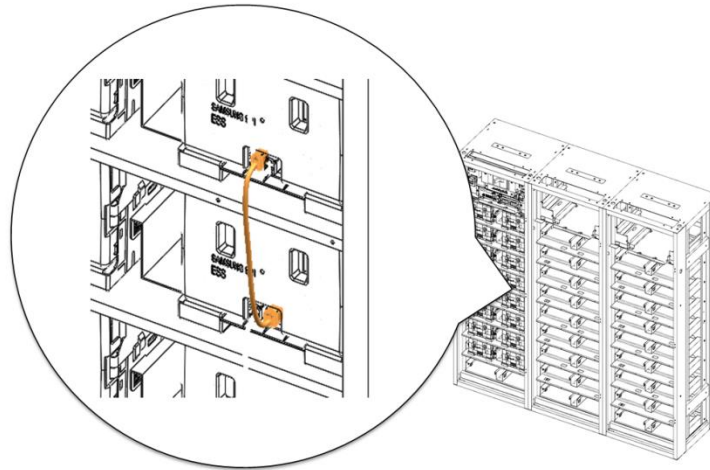

Figure 2-44: Module #4 to Module #5 Signal Cabling

6. Connect the signal cable "WIRE ASSY MODULE TO MODULE #1" from Module #5 "IN" to Module #6 "OUT".

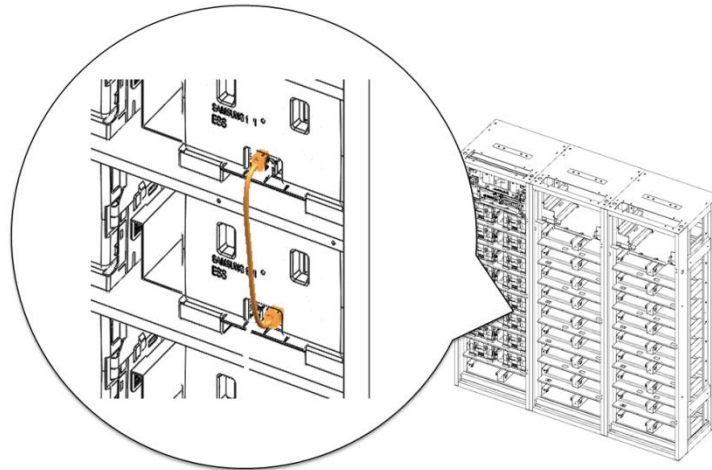

Figure 2-45: Module #5 to Module #6 Signal Cabling

7. Connect the signal cable "WIRE ASSY MODULE TO MODULE #1" from Module #6 "IN" to Module #7 "OUT".

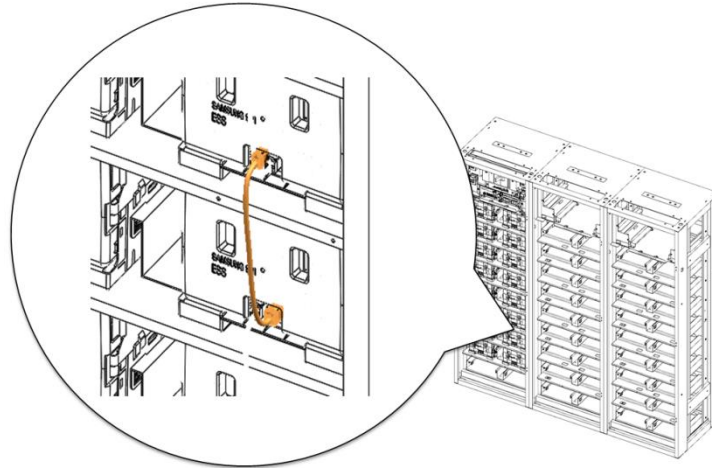

Figure 2-46: Module #6 to Module #7 Signal Cabling

Signal cables connecting Module #7 to #8, #8 to #9 and #9 to #10 will be installed in 2.8.9 Rack Fuse and Additional Module Signal Cable Connection.

8. Connect the signal cable "WIRE ASSY MODULE TO MODULE #1" from Module #10 "IN" to Module #11 "OUT".

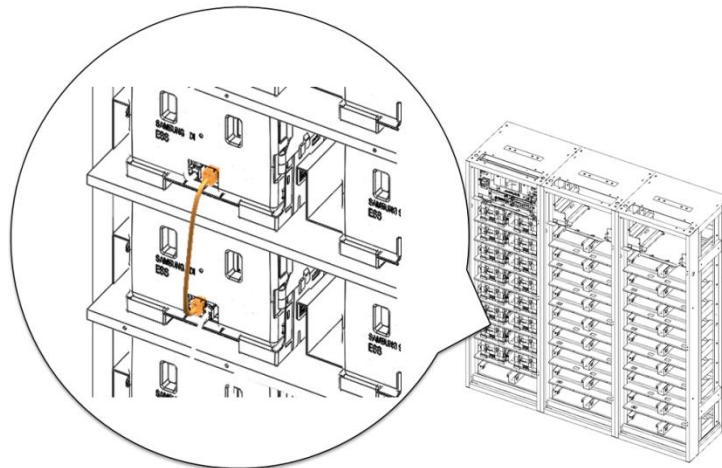

Figure 2-47: Module #10 to Module #11 Signal Cabling

2. Installing the Product

9. Connect the signal cable "WIRE ASSY MODULE TO MODULE #1" from Module #11 "IN" to Module #12 "OUT".

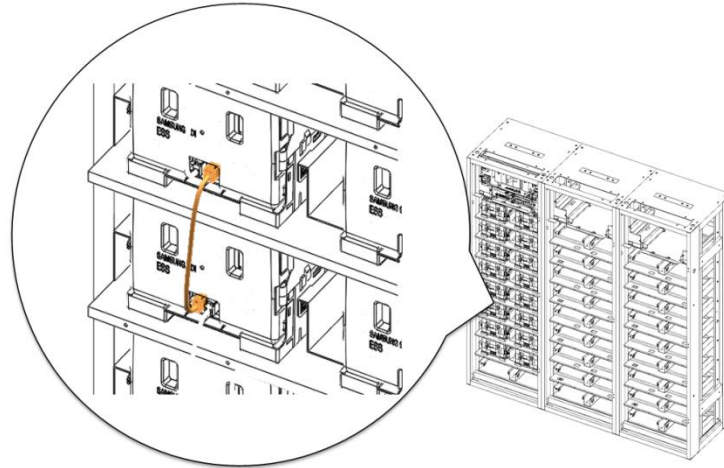

Figure 2-48: Module #11 to Module #12 Signal Cabling

10. Connect the signal cable "WIRE ASSY MODULE TO MODULE #1" from Module #12 "IN" to Module #13 "OUT".

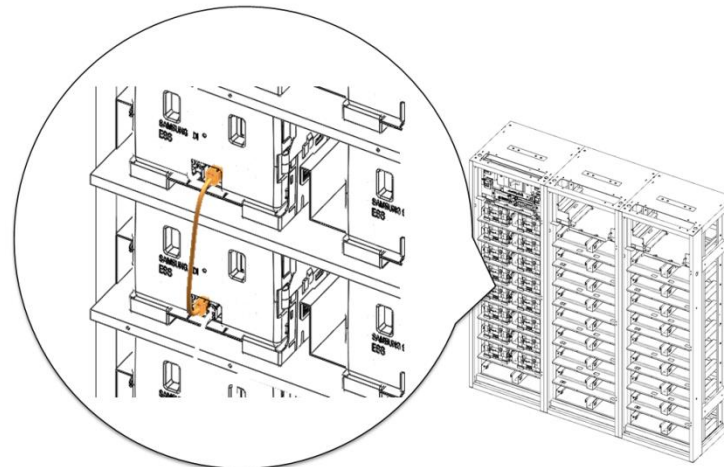

Figure 2-49: Module #12 to Module #13 Signal Cabling

11. Connect the signal cable "WIRE ASSY MODULE TO MODULE #1" from Module #13 "IN" to Module #14 "OUT".

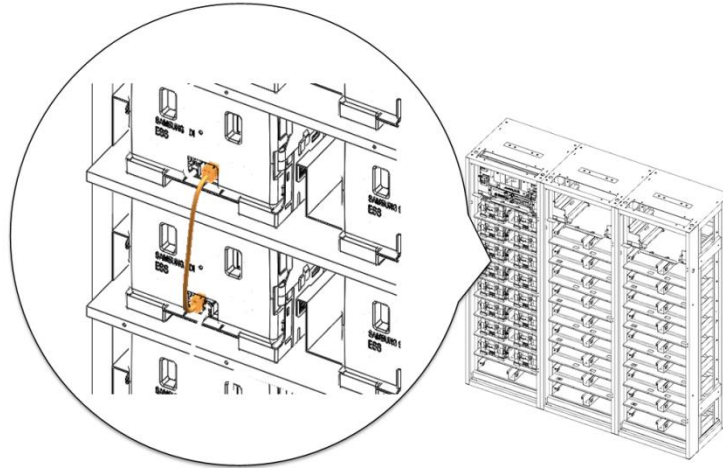

Figure 2-50: Module #13 to Module #14 Signal Cabling

12. Connect the signal cable "WIRE ASSY MODULE TO MODULE #1" from Module #14 "IN" to Module #15 "OUT".

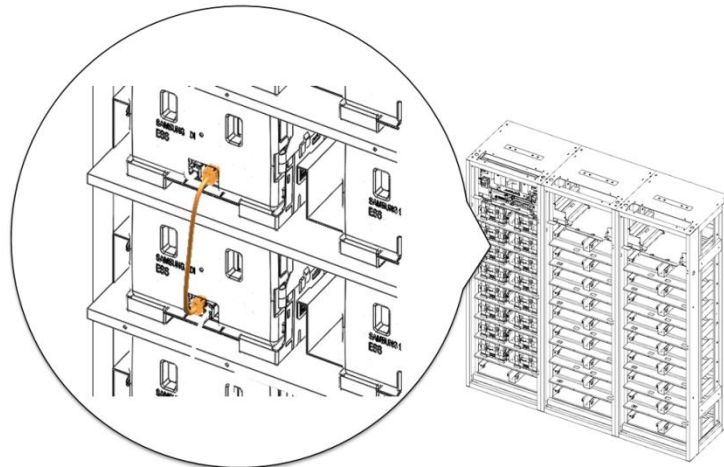

Figure 2-51: Module #14 to Module #15 Signal Cabling

13. Connect the signal cable "WIRE ASSY MODULE TO MODULE #1" from Module #15 "IN" to Module #16 "OUT".

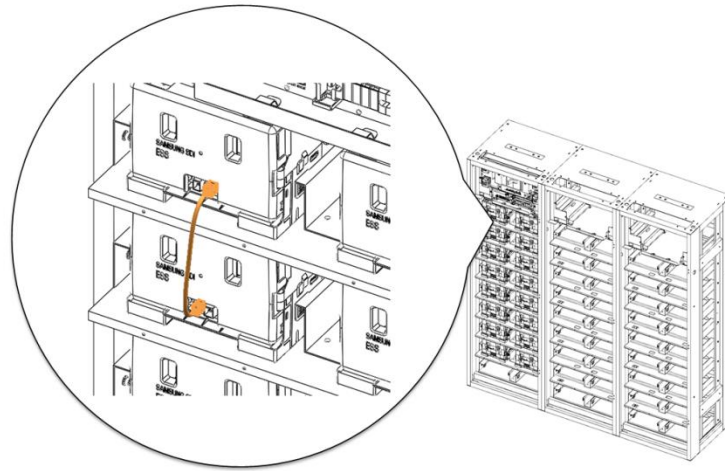

Figure 2-52: Module #15 to Module #16 Signal Cabling

14. For multiple rack system, connect the signal cables “WIRE ASSY RACK TO RACK #2” between each rack’s switchgear. Push the circular Hole part to pass the cable through a circular hole in the side of the rack frame and through the opening above Module #1 and Module #16

**NOTICE**

- See the examples for correct signal cable wire connection for both left and right Rack alignments.

**Important**

To connect the signal cables between Switchgear Assemblies:

- Connect the signal cable from the left port of Switchgear #1 CAN to the right port of Switchgear #2 CAN.
- Repeat for the remaining Switchgear Assemblies.
- Slide the switch to the “ON” position for the last Switchgear.

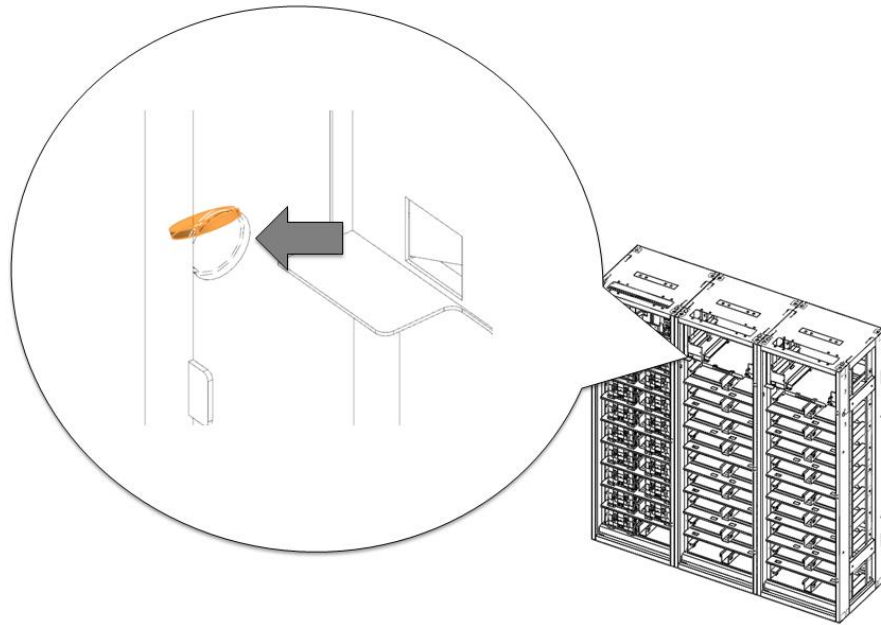

Figure 2-53: Pushed Hole Examples of Left Alignment of Switchgears

2. Installing the Product

Signal Cabling Examples of Left Alignment of Trays

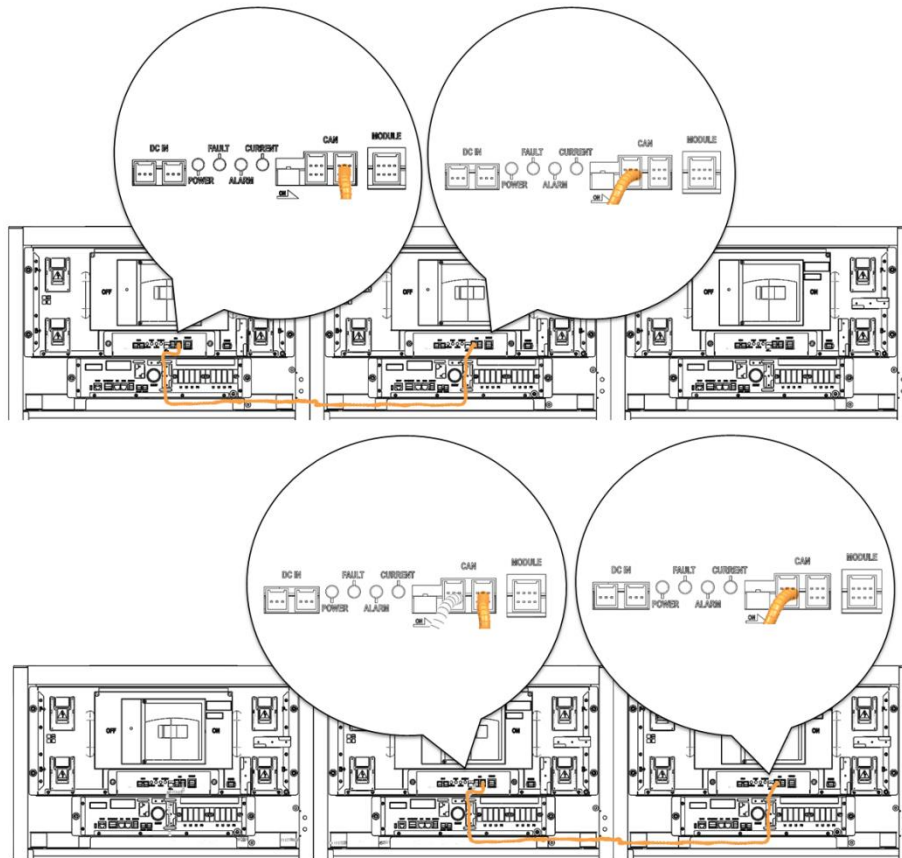

Figure 2-54: Signal Cabling Examples of Left Alignment of Switchgears

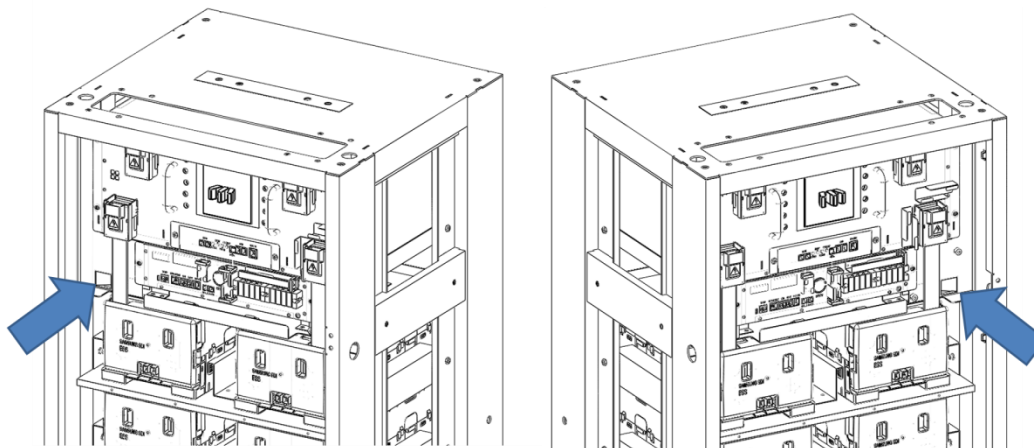

Figure 2-55: Openings for Cable

15. Turn the termination resistor switch on for the last Switchgear in the CANbus loop.

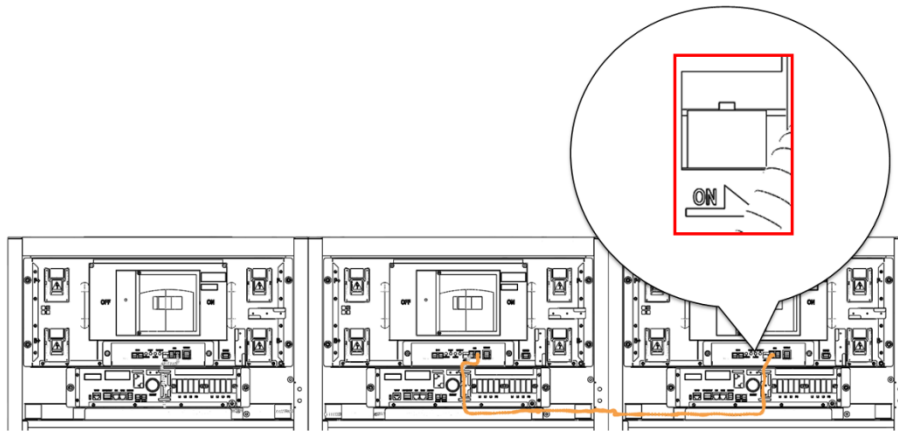

Figure 2-56: Termination Resistor Setting for Last Switchgear



NOTICE

- Factory-provided cables are adequate for systems with Rack Frames bolted together. Different configurations may require cable modification.

2.8.5 Switchgear Signal Cable Connection for Rear-to-Rear Installation

For multiple rear-to-rear rack installation, connect the longer signal cable “WIRE ASSY RACK TO RACK_2500” between the switchgears that are connected from front to rear.

	NOTICE
	<ul style="list-style-type: none"> Please use the 2.5m rack to rack signal cable as specified by the part numbers below.

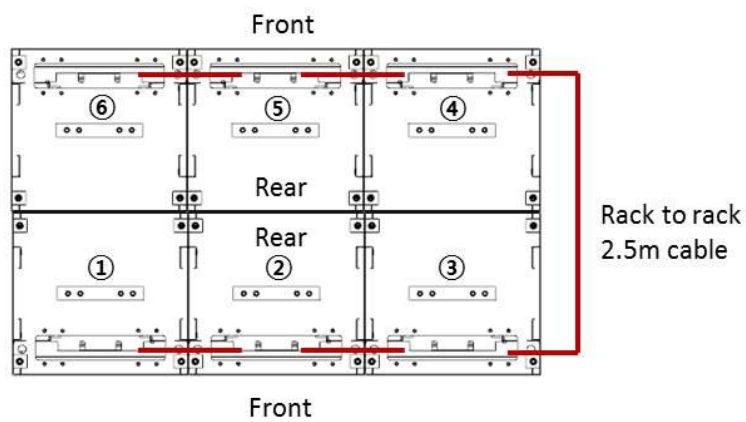

Figure 2-57: Signal Cabling Example – Rear-to-rear connection on the right side

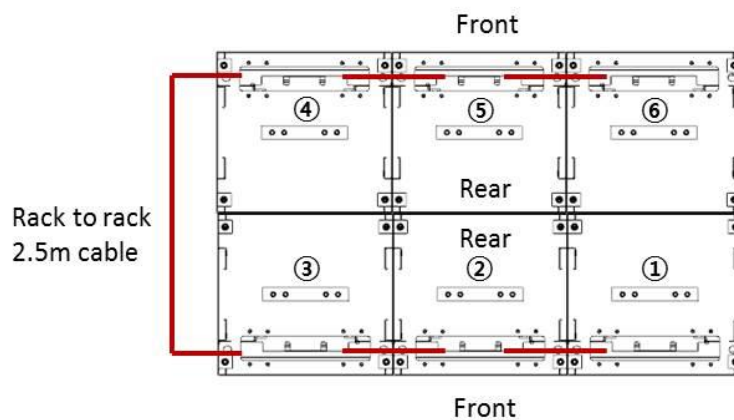

Figure 2-58: Signal Cabling Example – Rear-to-rear connection on the left side

2.8.6 SMPS Assembly and Switchgear Power Cable Connection

Connect Switchgear DC power cables.

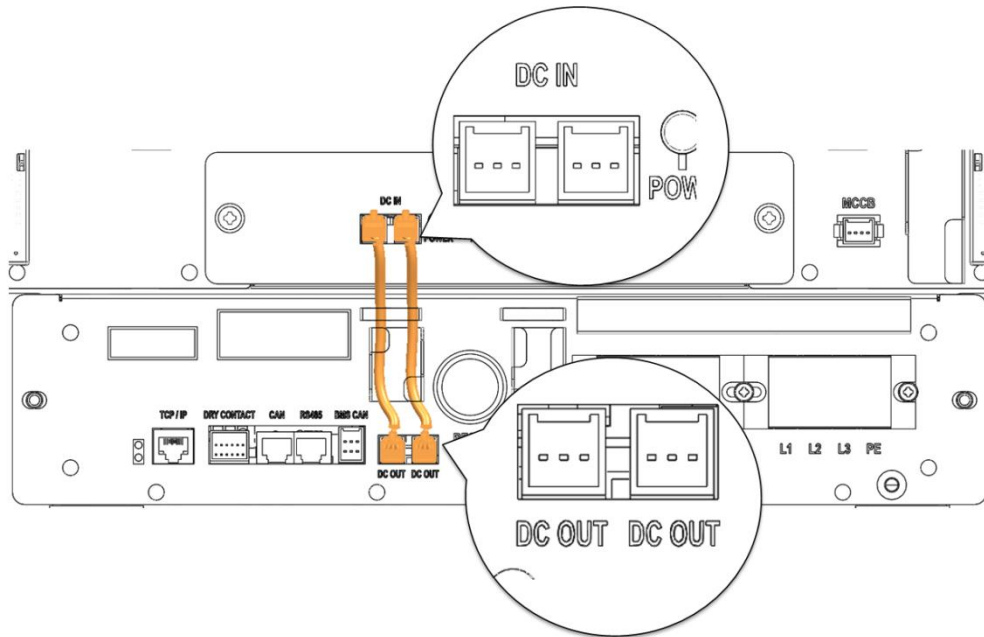

Figure 2-59: DC Power Cables from SMPS Assembly Type A to Switchgear

2.8.7 SMPS Assembly and Switchgear Signal Cable Connection

The following steps are only for the SMPS Assembly that is used as the System BMS.

1. Connect signal cable from SMPS Assembly to Switchgear “WIRE ASSY RACK TO SYSTEM”

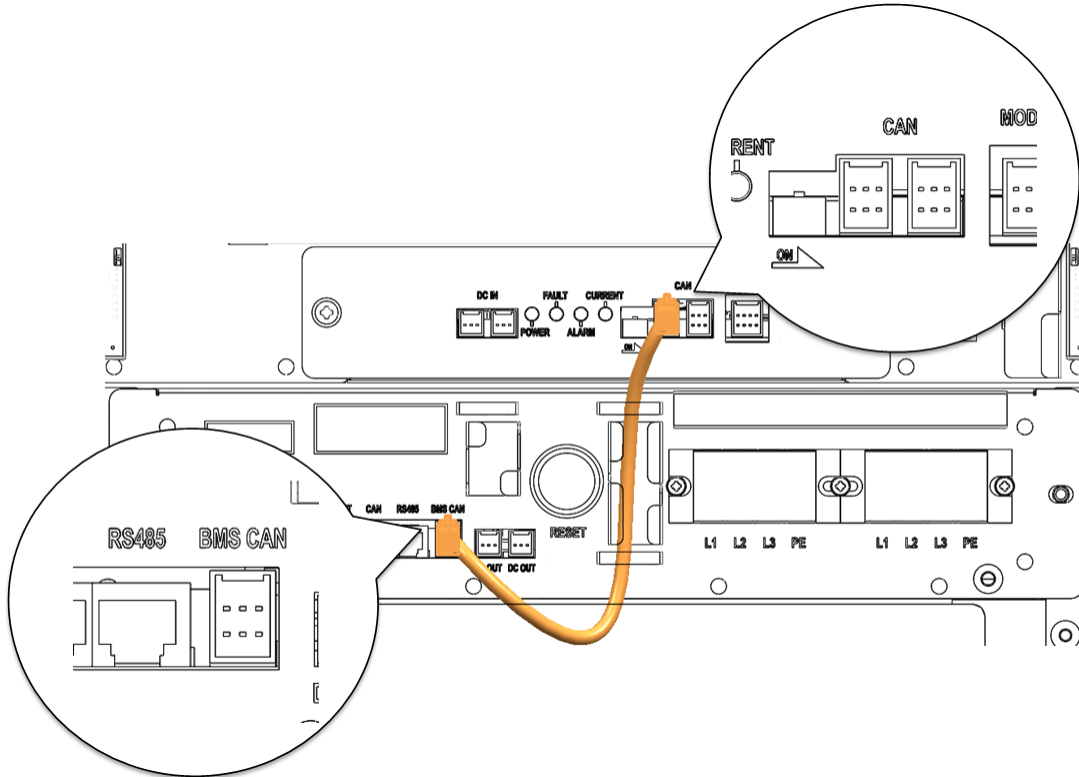

Figure 2-60: CAN Signal Cable Connection from SMPS Assembly to Switchgear

1. Connect SMPS Assembly TCP/IP Cable⁴

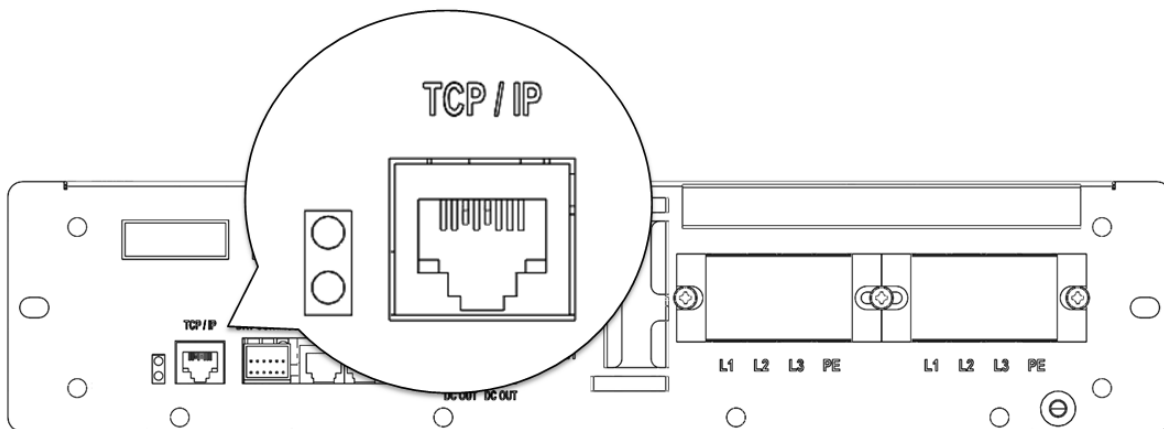

Figure 2-61: TCP/IP Cable Connection to SMPS Assembly

⁴ Not factory-provided. Must be provided by the installer or customer

2. Connect SMPS Assembly Dry Contact Cable⁵

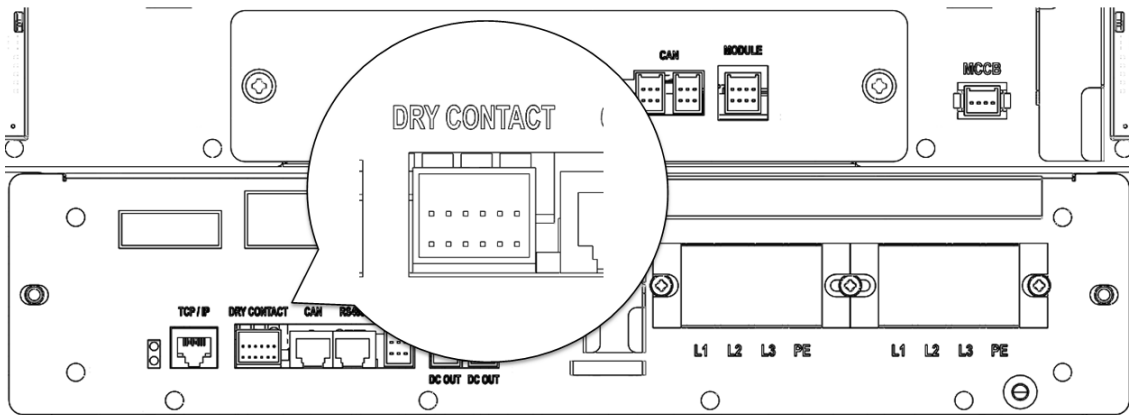

Figure 2-62: Dry Contact Cable Connection to SMPS Assembly

3. Connect Switchgear MCCB Cable⁶

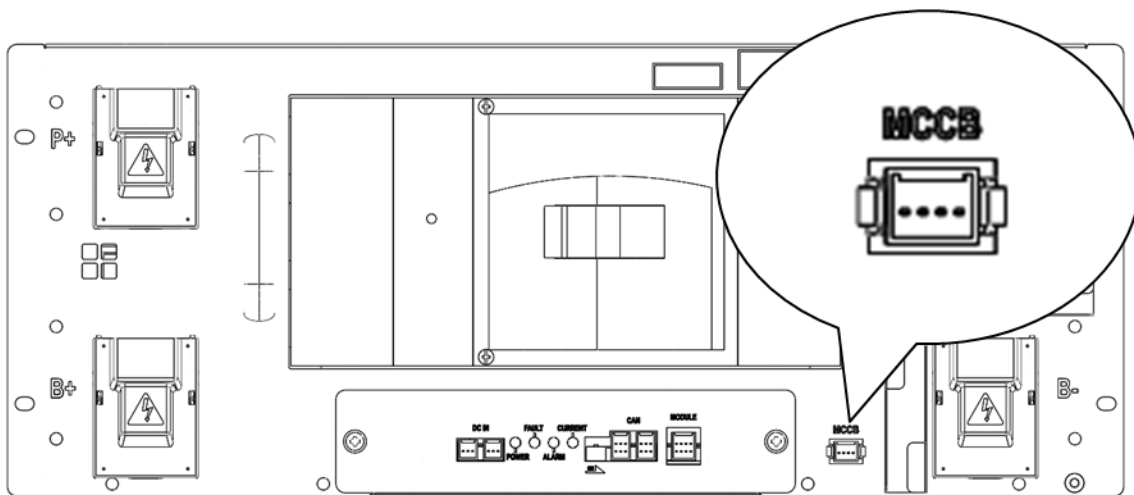

Figure 2-63: MCCB Extra Auxiliary Connection

⁵ Not factory-provided. Must be provided by the installer or customer

⁶ Not factory-provided. Must be provided by the installer or customer

2.8.8 SMPS Assembly AC Input Connection

1. Remove the protective covers of the AC input terminals

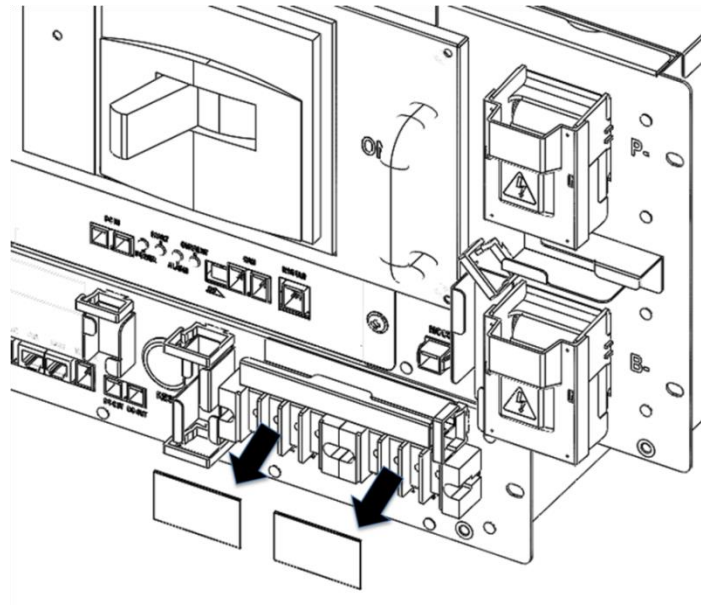

Figure 2-64: AC Input Terminals

2. Connect each AC inputs in the SMPS Assembly. Make sure the AC cables are not energized.⁷

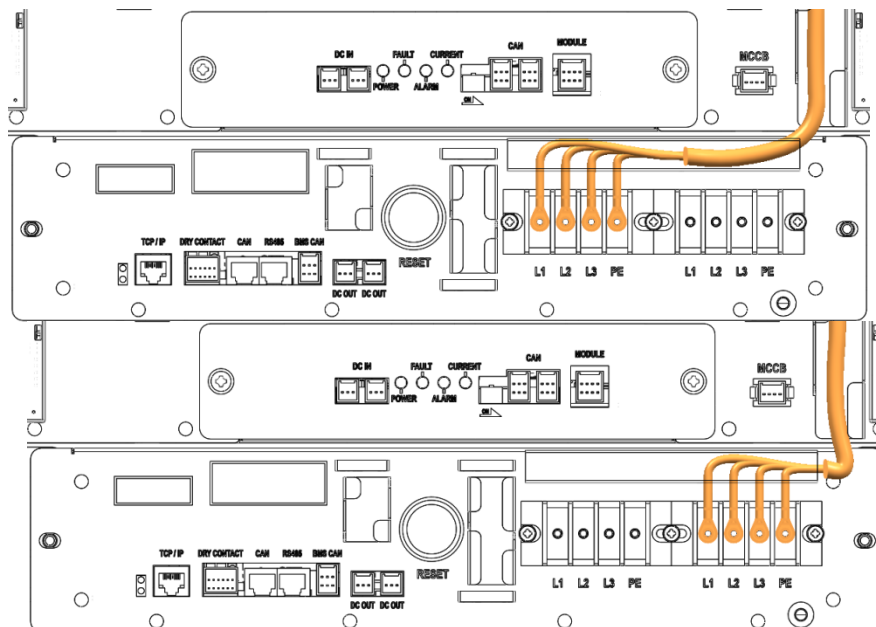

Figure 2-65: AC Input Terminals with Cables Attached

⁷ AC Cables are not factory-provided. They must be provided by the installer or customer.

3. Reattach the protective covers to the AC input.

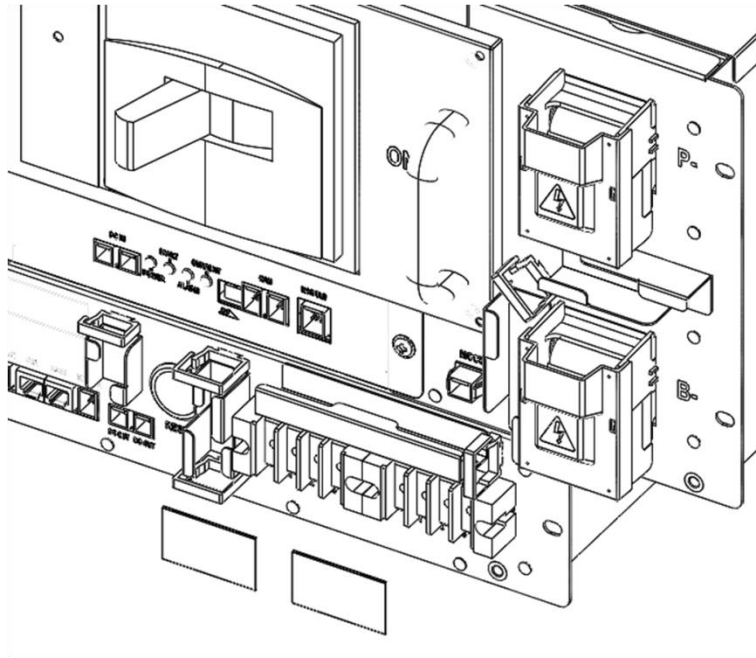



Figure 2-66: AC Input Terminals Protective Covers

2.8.9 Rack Fuse and Additional Module Signal Cable Connection

	NOTICE
<p>Rack fuse cover must be installed to the fuse to prevent the exposure of live electrical parts.</p>	

1. Remove battery module front covers for module #8 and module #9.

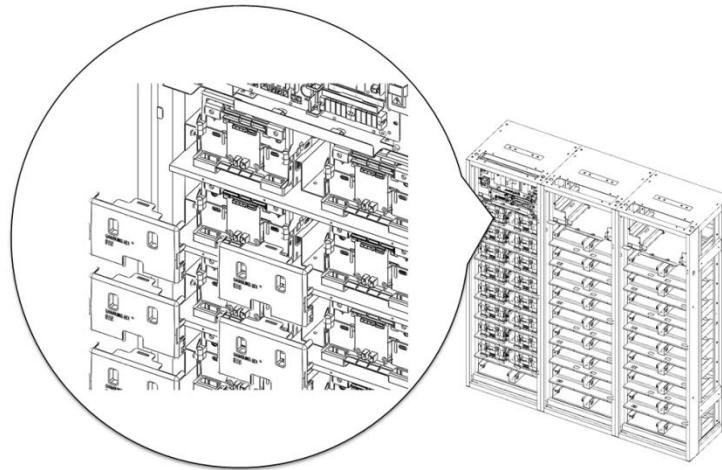



Figure 2-67: Remove Module #8 and Module #9 Front Cover

2. Assemble the Rack fuse Bus-bar assembly. Rack fuse bus-bar assembly is comprised of one "RACKFUSE BUSBAR_R_128S", one "RACKFUSE BUSBAR_L_128S", two "SCREW M12 X 16" and one "FUSE".

	NOTICE
<p>Rack Fuse Bus Bar Assembly is assembled at the site of installation. M12 X 16L screws are used to assemble the bus bars and fuse. The fastening torque should be 30 N·m/300 kgf·cm.</p>	

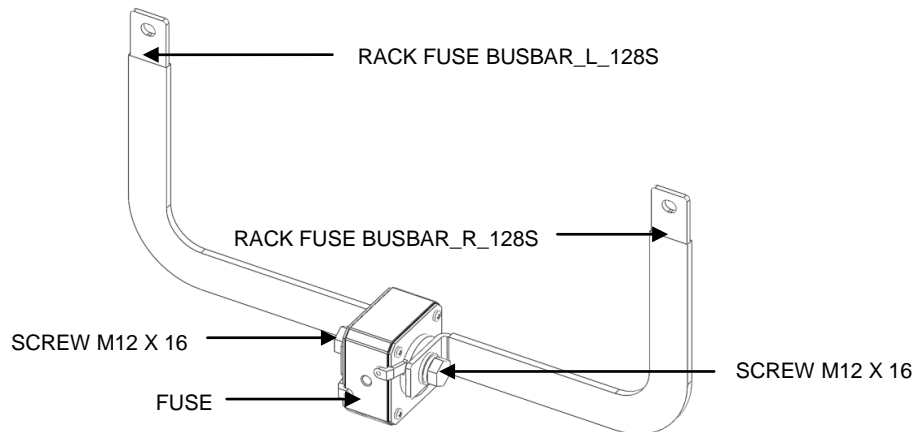

Figure 2-68: Rack Fuse Bus-bar Assembly.

3. Assembly Rack Fuse Cover "FUSE COVER"

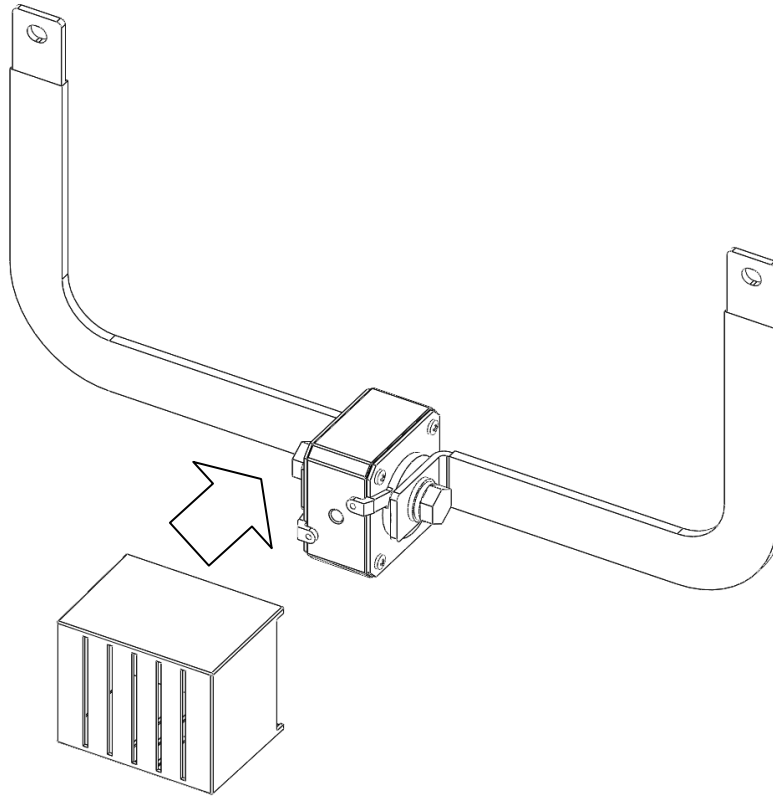

Figure 2-69: Rack Fuse Cover

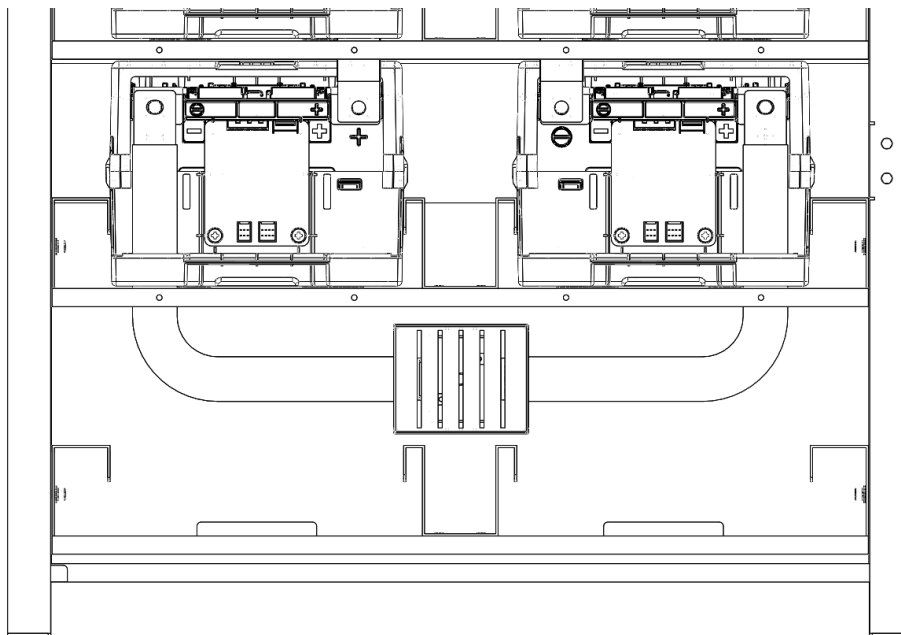

Figure 2-70: Rack Fuse Cover (Fully Assembled Front View)

2. Installing the Product

4. Assemble Module #8 and Module #9 Front Cover

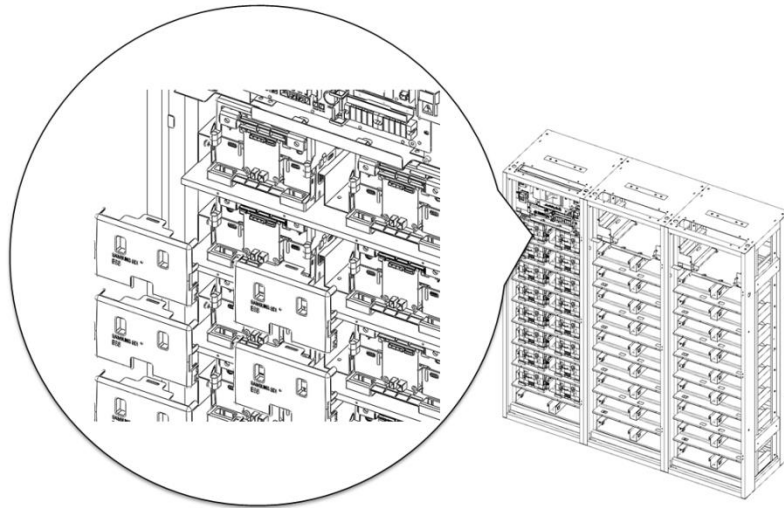

Figure 2-71: Assemble Module #8 and Module #9 Front Cover

5. Connect the signal cable "WIRE ASSY MODULE TO MODULE #1" from Module #7 "IN" to Module #8 "OUT".

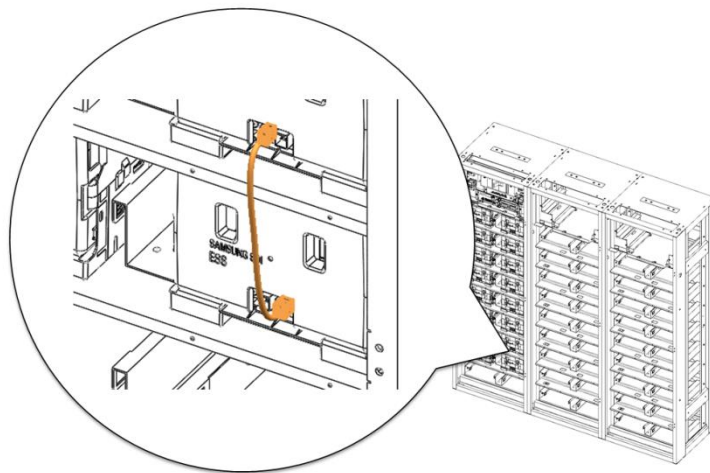

Figure 2-72: Module #7 to Module #8 Signal Cabling

6. Connect the signal cable "WIRE ASSY MODULE TO MODULE #2" from Module #8 "IN" to Module #9 "OUT".

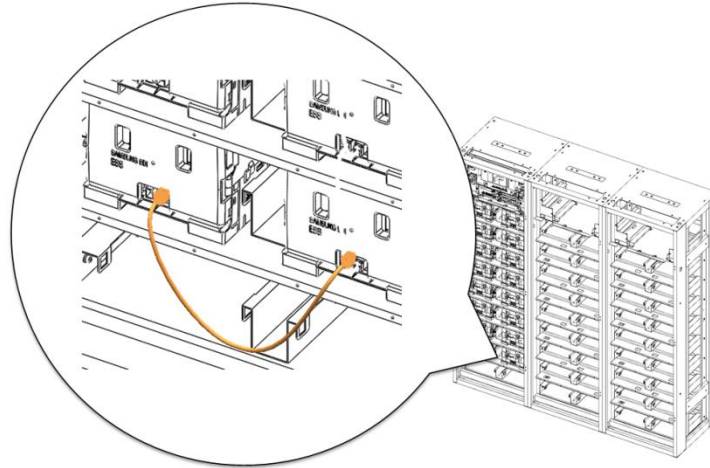

Figure 2-73: Module #8 to Module #9 Signal Cabling (WIRE ASSY MODULE TO MODULE #2)

7. Connect the signal cable "WIRE ASSY MODULE TO MODULE #1" from Module #9 "IN" to Module #10 "OUT".

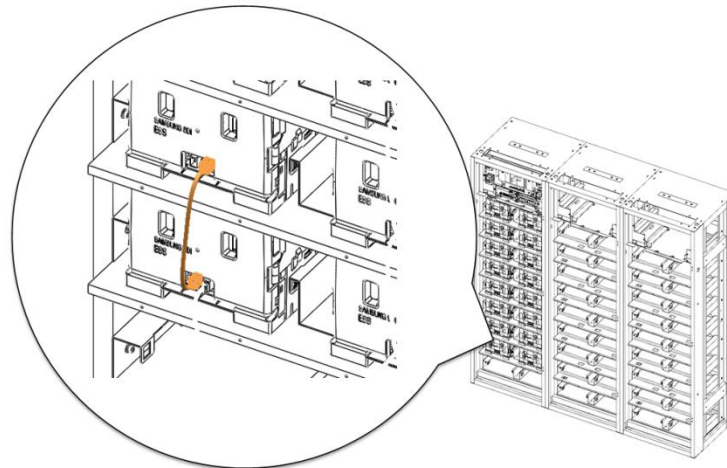

Figure 2-74: Module #9 to Module #10 Signal Cabling

2.8.10 DC Link Cable Connection

1. Connect the ground cables.

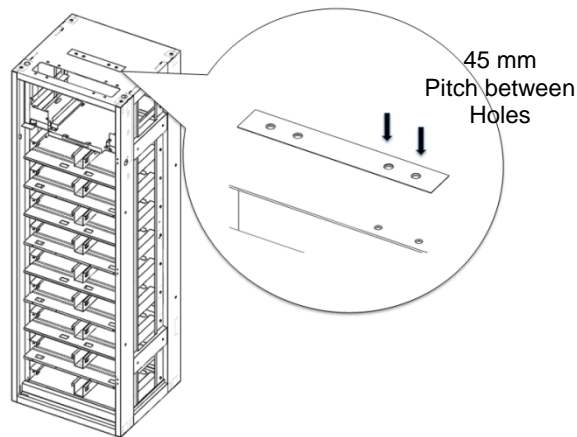

Figure 2-75: Grounding Points (2 EA)

Ground connections are provided on the bottom and on the top of the rack. Either may be used for grounding.

	NOTICE
	<ul style="list-style-type: none"> Connect the rack ground wire with an M12 screw. Rack ground screws are not factory-provided and must be provided by the installer or customer. The fastening torque should be 30Nm (300kgf·cm).

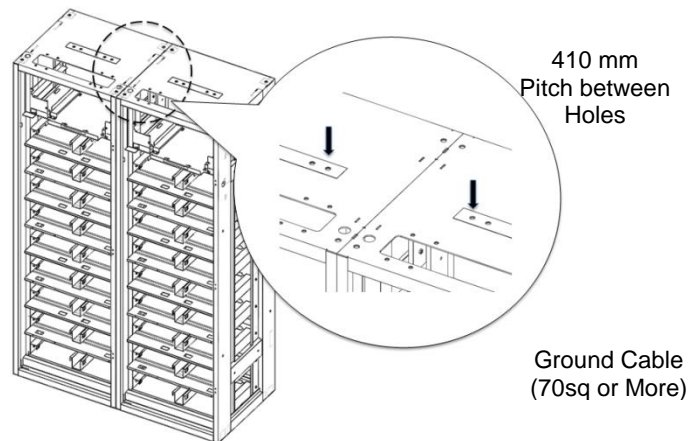

Figure 2-76: Connection of Ground Cable for Multiple Rack Frames

2. Connect the DC link high current cables from the UPS.

**CAUTION**

- Make sure that the high current cables are LOTO'ed before this step.
- In this step, the battery and UPS are isolated by the switchgear because the circuit breaker in the switchgear is opened.

**NOTICE**

- Connect the high current cables using an M12 screw.
- The fastening torque should be 30 N·m/300 kgf·cm.

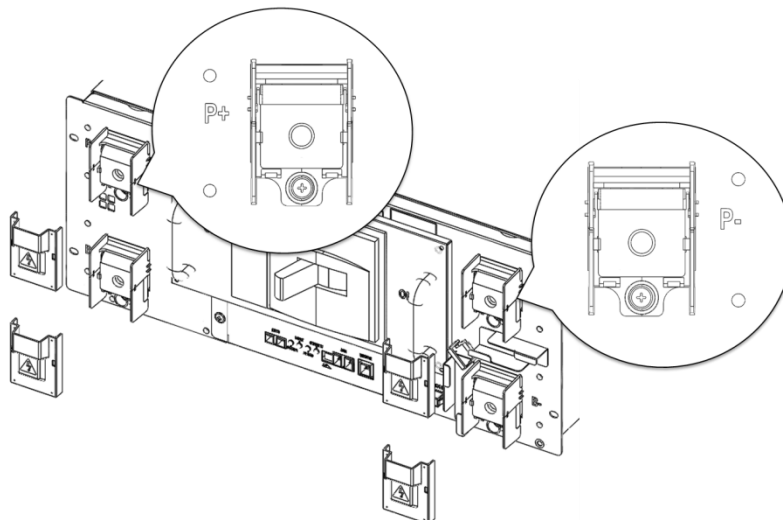
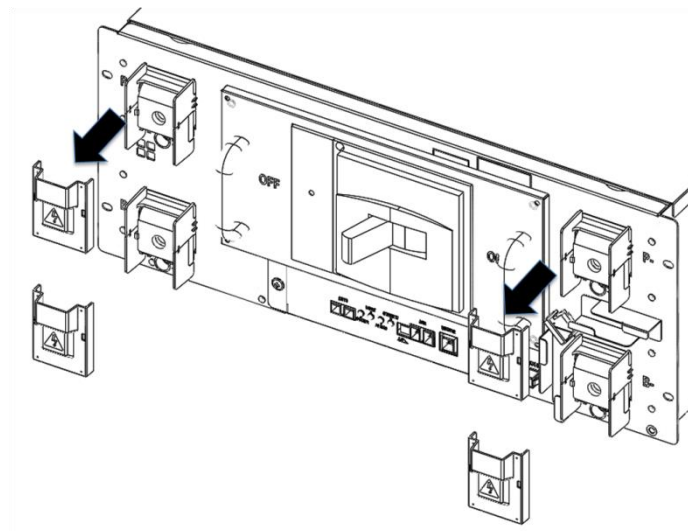

Figure 2-77: Connecting the DC Link High Current Cables

After installation is completed, check the following:

2. Installing the Product

- Bolt fastening condition
- Screw fastening torque by sampling
- High voltage cable connection
- Module connections
- Switchgear connections

2.8.11 AC Input Commissioning

When the installation of the battery system is completed, SMPS Assembly's AC inputs must be powered to turn the BMS on.

2.8.12 Switching On MCCB

After powering the battery system's SMPS Assembly and Switchgear on, check the indicator LED to check if the system is in normal status. Refer to the "Product Specification" and "Operations and Maintenance Manual" for information on the indicator LED.



CAUTION

- Follow the instruction and guidelines for the UPS on connecting the battery to the UPS before switching the MCCB on.

MCCB in the Switchgear will be in "TRIP" position during installation.

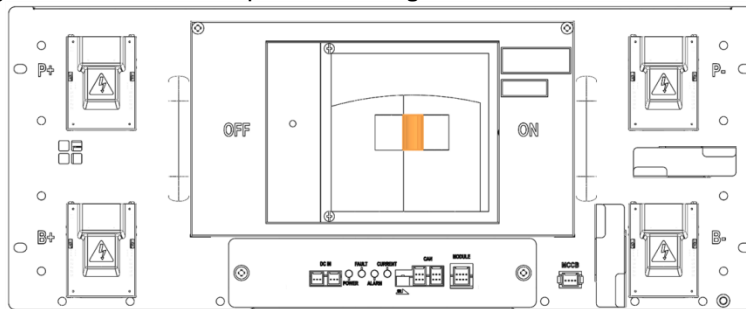

Figure 2-78: MCCB Handle in Trip Position

Shift the handle of the MCCB to "OFF"

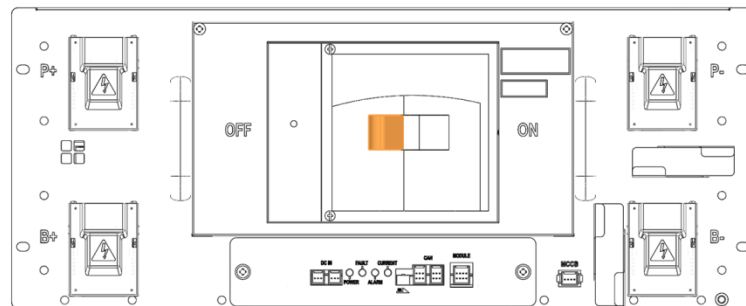



Figure 2-79: MCCB Handle in Off Position





Then Shift the handle to "ON" to connect the battery system to the UPS DC link.

2.8.13 BMS Configuration

	NOTICE
<ul style="list-style-type: none"> ▪ It is recommended that the configuration of the Rack BMS and System BMS be done by experienced service personnel. Incorrect configuration of the Rack BMS and System BMS will cause communication failure. 	

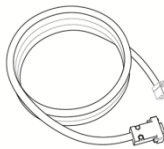
Prepare the following items and configure the Rack BMS and System BMS.

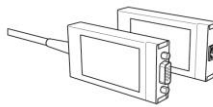
Table 2-10: Required Items for BMS Configuration

No.	Items	Appearance	Comments
1	Rack BMS ID Writer Cable		J21SF-06V-KX-L (6 pin) and D-SUB female (9 pin) Connect between Rack BMS and USB-to-CAN device. Must be made by customer or installer as described below (Table 2-11: Rack BMS ID Writing Cable Pin Map)
2	System BMS Configuration Cable		RJ45 (8 pin) and D-SUB female (9 pin) Connect between System BMS and USB-to-CAN device Must be made by customer or installer as described below (Table 2-12: System BMS Configuration Cable Pin Map)
3	Ethernet Cable		RJ45 (8 pin) and RJ45 (8 pin) Must be made by customer or installer as described below (Table 2-13: System BMS Communication Cable Pin Map)
4	IXXAT USB-to-CAN V2		Must be sourced by customer or installer. Driver must be installed on the computer.
5	Notebook PC Windows 7 SP1 (English) recommended		Must be sourced by customer or installer. Service pack: SP1 Minimum hardware requirements <ul style="list-style-type: none"> • 1 GHz or faster 32-bit processor • 1 GB RAM (32-bit) or 2 GB RAM (64-bit) • 16 GB available hard disk (32-bit) or 20 GB (64-bit)

2. Installing the Product



NOTICE

- The Rack BMS ID writing cable, System BMS configuration cable and Ethernet Cable must be made by the customer or installer according to the following PIN map.

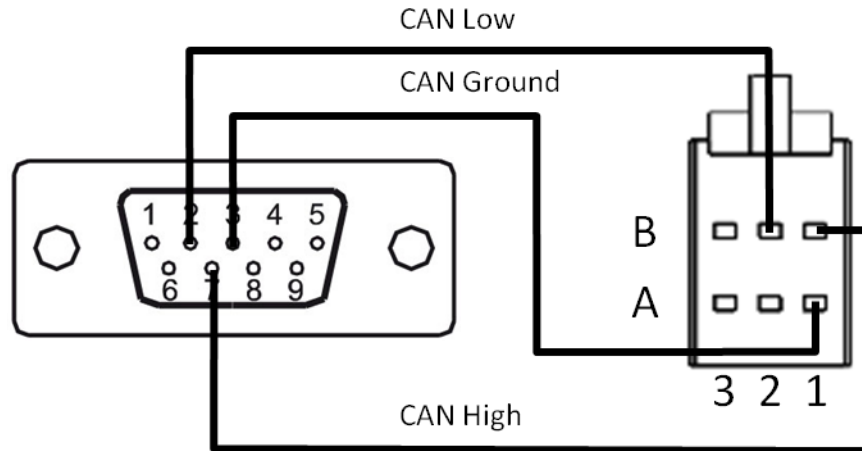

Figure 2-81: Rack BMS ID Writing Cable Pin Map

Table 2-11: Rack BMS ID Writing Cable Pin Map

Connection A			Connection B		
Connector	Pin No.	Signal	Connector	Pin No.	Signal
D-SUB (Female)	1	-	J21SF-06V-KX-L	1A	GND Ground
	2	CAN Low		2A	-
	3	CAN Ground		3A	-
	4	-		1B	CAN High
	5	-		2B	CAN Low
	6	-		3B	-
	7	CAN High			
	8	-			
	9	-			

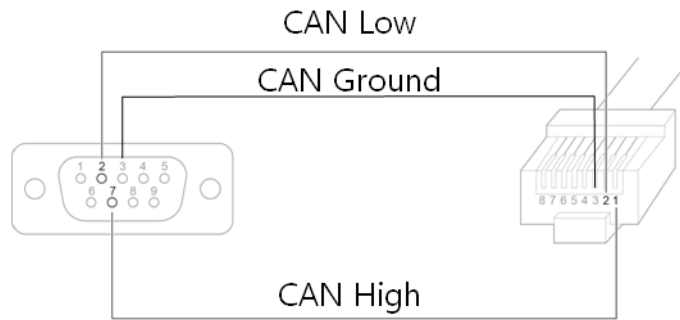

Figure 2-82: System BMS Configuration Cable Pin Map

Table 2-12: System BMS Configuration Cable Pin Map

Connection A			Connection B		
Connector	Pin No.	Signal	Connector	Pin No.	Signal
D-SUB (Female)	1	-	RJ45	1	CAN High
	2	CAN Low		2	CAN Low
	3	CAN Ground		3	CAN Ground
	4	-		4	-
	5	-		5	-
	6	-		6	-
	7	CAN High		7	-
	8	-		8	-
	9	-			

NOTICE

- A 120 Ω termination resistor must be inserted between the pins for No 2 and No 7 in the D-SUB (Female).

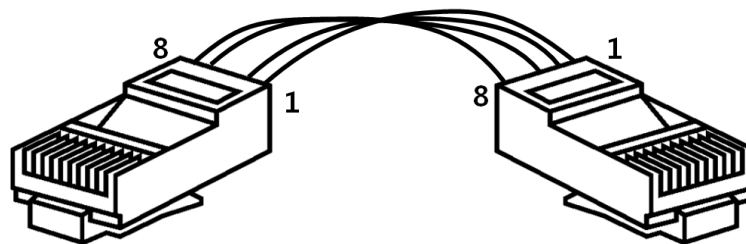

Figure 2-83: System BMS Communication Cable Pin Map

Table 2-13: System BMS Communication Cable Pin Map

Connection A			Connection B		
Connector A	Pin No.	Signal	Connector B	Pin No.	Signal
RJ45	1	Tx+	RJ45	1	Tx+

2. Installing the Product

Connection A			Connection B		
Connector A	Pin No.	Signal	Connector B	Pin No.	Signal
	2	Tx-		2	Tx-
	3	Rx+		3	Rx+
	4	-		4	-
	5	-		5	-
	6	Rx-		6	Rx-
	7	-		7	-
	8	-		8	-

Download the IXXAT installation driver from the website at <http://www.ixxat.com/support/file-and-documents-download/drivers/vci-v3-driver-download> and install the driver on the computer.

2. Installing the Product

2. Run “ELP_MON.exe” after turning on Rack BMS. This program is provided to the customer.



Figure 2-86: Rack & System Monitoring Program

3. Click the **INSTALL**(①) tab for installation.

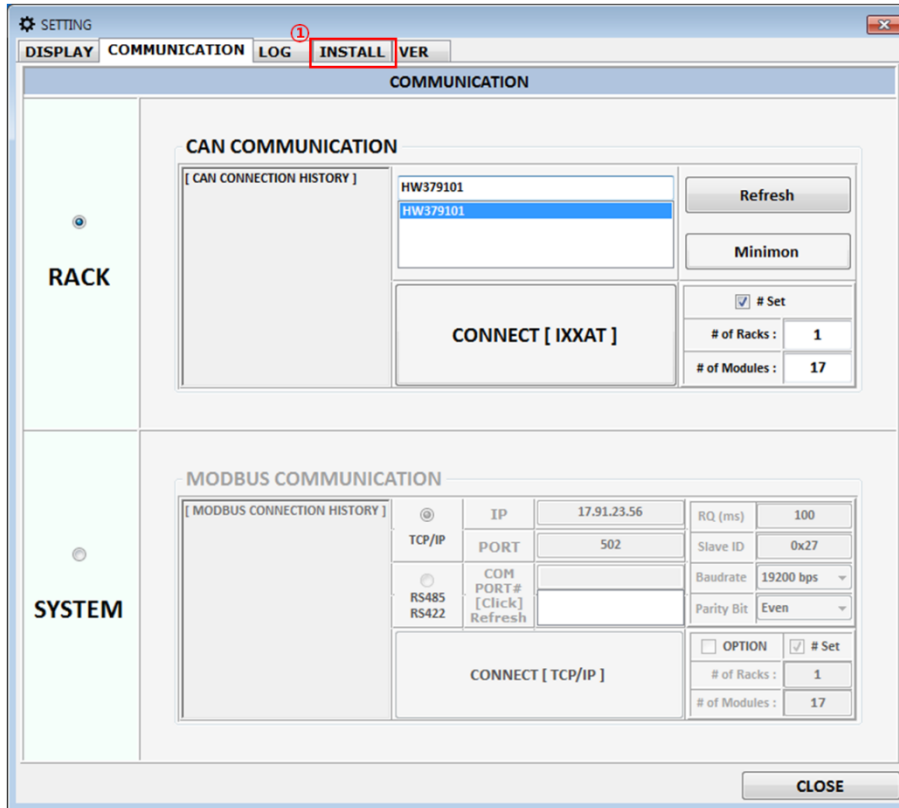

Figure 2-87: Monitoring Program Window

4. In **INSTALL** tab, select [**RACK**] (①) and select the appropriate Device HW number and click ‘**CONNECT**’(②).
When connection is completed, button text is changed from ‘CONNECT’ to ‘**DISCONNECT**’(③).

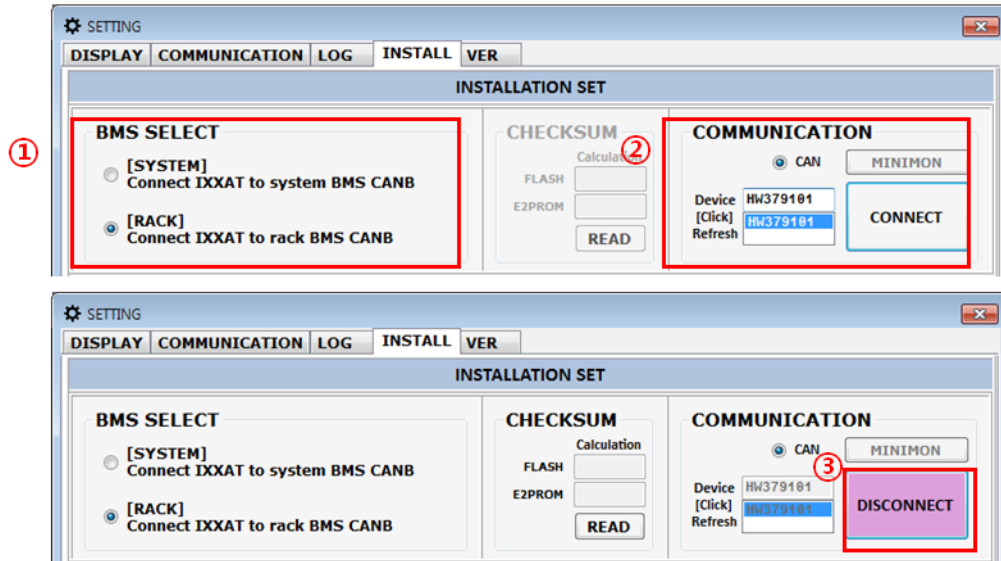

Figure 2-88: RACK BMS Installation Window



Figure 2-89: Displayed Window when Connected

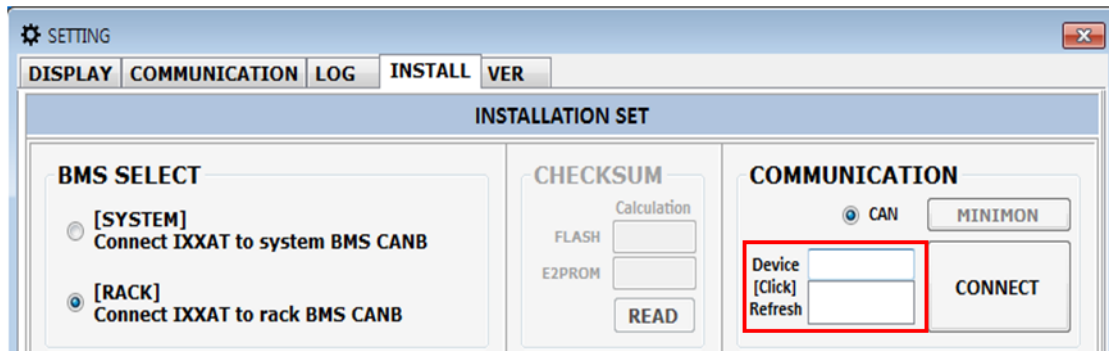



Figure 2-90: Device box is empty when USB-to-CAN device is not connected

	NOTICE
	<ul style="list-style-type: none"> ▪ When the USB-to-CAN device is not connected to your computer, CONNECT button will not work.

5. If any item's value needs to be changed, click the cell under 'Write Value' column, type in the new value and **check** the **checkbox [V]** (①). If you want to change the value of all racks, **check** the '**Default ID**', and if you want to change single rack's value of Item, **uncheck** the '**Default ID**' and **select ID**(②). After entering the new values

2. Installing the Product

under 'Write Value' column, click the **'WRITE VALUE'** button (③). When you click the button, the same value automatically appears in 'Read Value' column. Finally, after clicking **'APPLY[RESET BMS]'**, Rack BMS reboots and the value that you changed is applied(④).

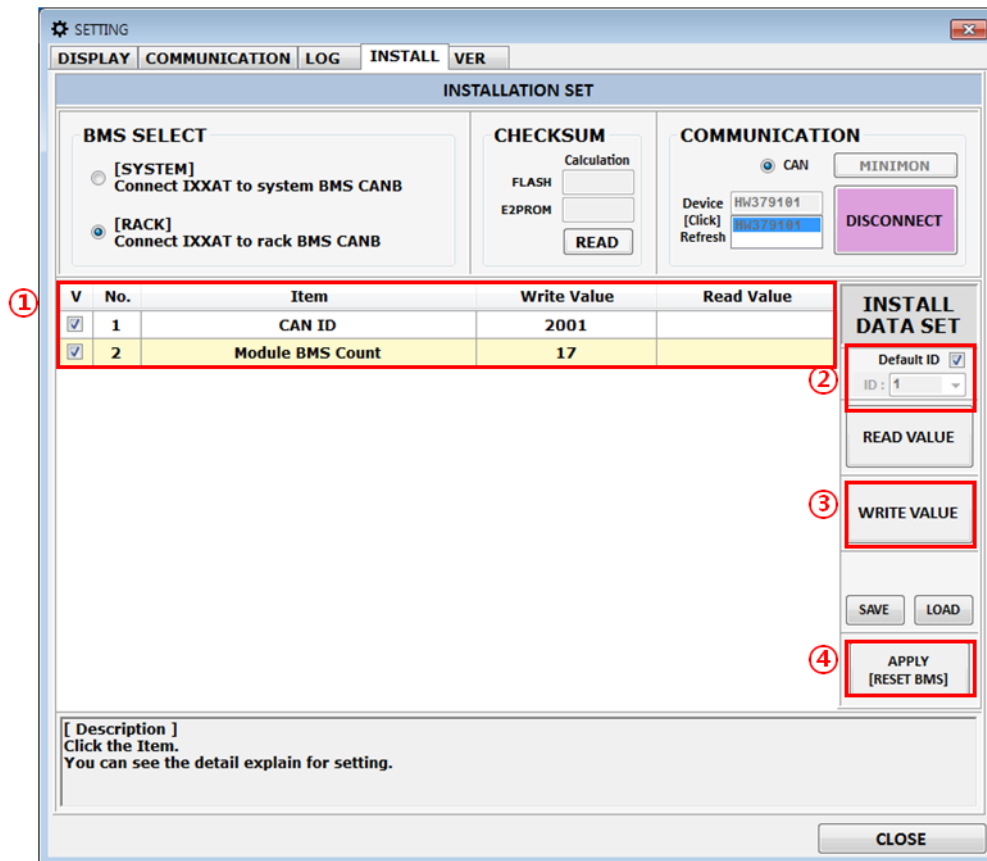



Figure 2-91: RACK BMS Installation Setting Window

	<p>Important</p> <ul style="list-style-type: none"> Number of Racks is the total number of racks (strings) installed. The possible range is 1–128. If the value exceeds the limit, the function cannot operate. In case of first rack, the value is 1. This value depends on the order of rack from system BMS. For example, if you want to set the second rack BMS, enter “2” under ‘Write Value’ then CAN ID 2002 is written for the second rack BMS. Number of Modules is the number of modules connected to the Rack BMS. Its possible range is 1–32. For example, in case of 128S1P Rack, the value is 16.
---	---

6. Close “ELP_MON.exe” and disconnect all signal cables from PC to Rack BMS.

7. If multiple racks are installed, repeat steps 1~6 for other racks.

2.8.13.2 System BMS Configuration

1. Connect both ethernet cable and configuration cable from the system BMS to your computer as the figure below.

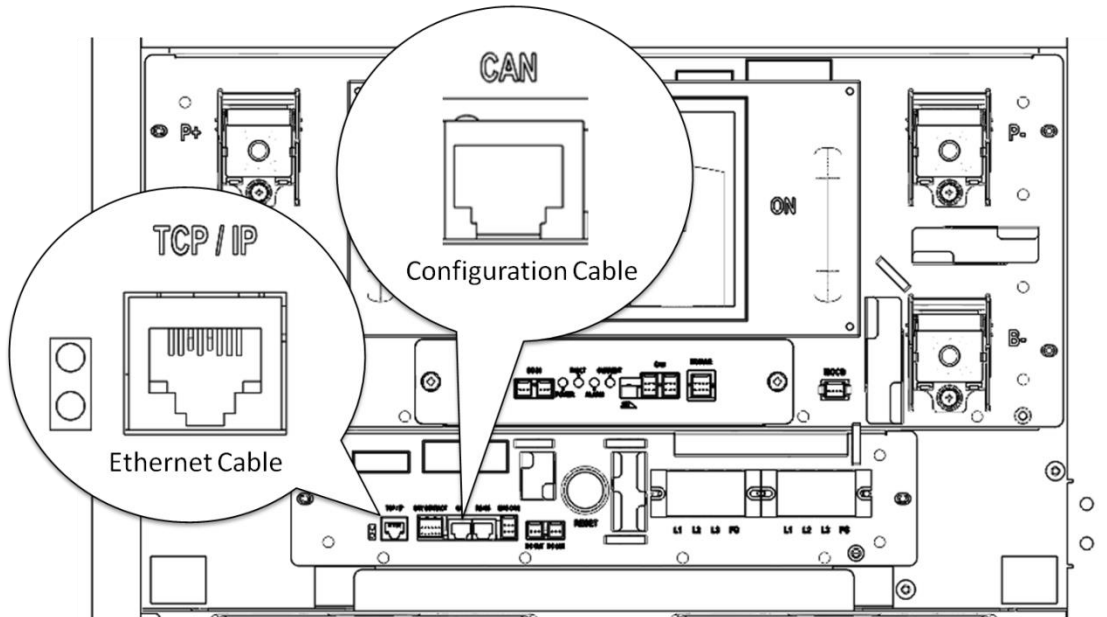



Figure 2-92: Cable Connections for System BMS Configuration

2. Run "ELP_MON.exe" (This program is provided to the customers)



Figure 2-93: Rack & System BMS monitoring program icon image

3. Click the **INSTALL**() tab for installation.

2. Installing the Product

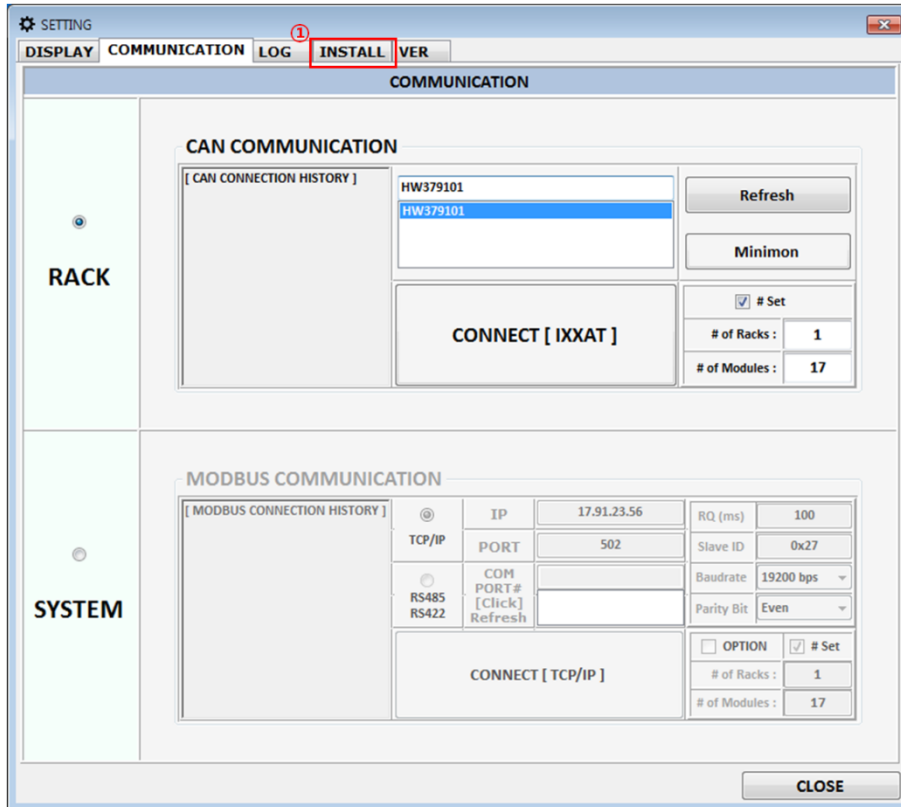

Figure 2-94: Communication Install Window

4. In **INSTALL** tab, select **[SYSTEM]** (①). And select the appropriate Device HW number and click **'CONNECT'**(②).
When connection is completed, button text is changed to 'CONNECT' to **'DISCONNECT'**(③).

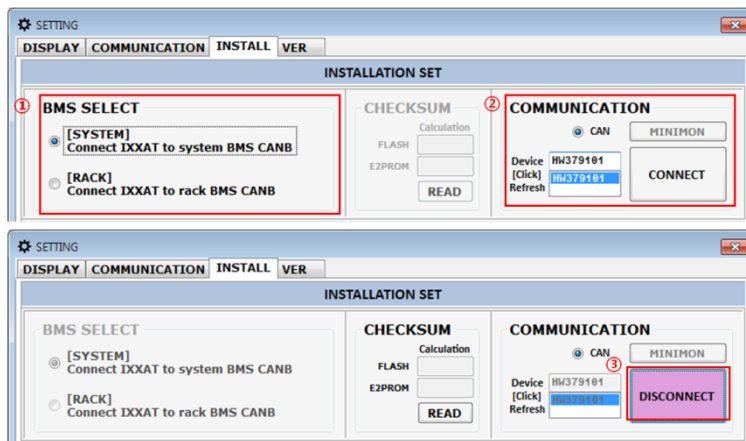

Figure 2-95: Install Window

5. If any value change is required, double-click the cell in Write Value and **check the checkbox [V]** (①). If you completed to change the data of 'Write Value', click the **'WRITE VALUE'** (②). When you clicked, the same value automatically appears in READ VALUE. Finally, after clicked **'APPLY[RESET BMS]'**, the SBMS reboots and the value that you changed is applied(③). Except the special case, check the 'Default ID' (④).

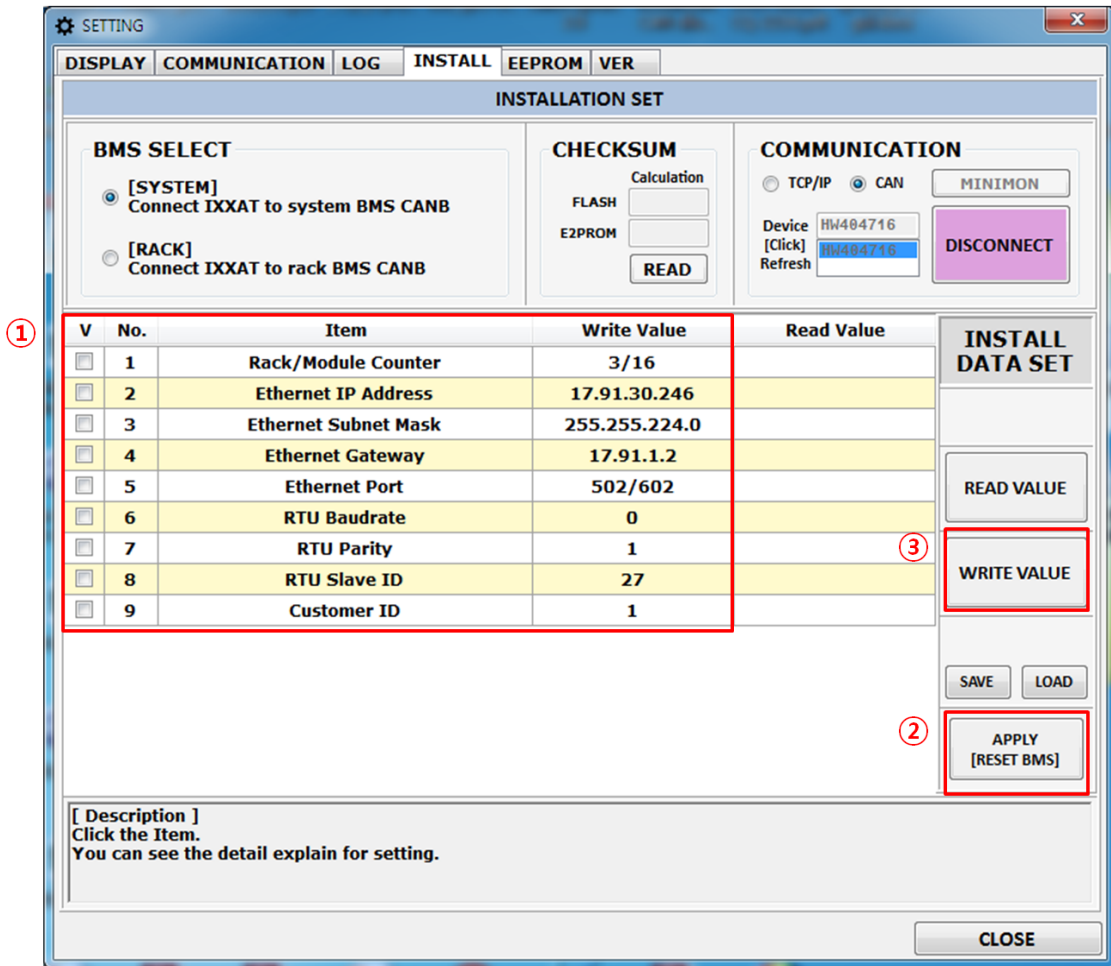



Figure 2-96: System BMS Install Setting Window

	<p>Important</p> <ul style="list-style-type: none"> You must change the values in ① according to your system configuration. Rack/Module Counter: Number of racks and modules per rack displayed. Number of Racks: Number of racks connected in parallel to the same UPS and connected to same System BMS Number of Modules: Number of modules for each rack (e.g., 128S1P Rack has 16 modules) Ethernet IP Address, Subnet Mask, Gateway, Port: TCP/IP address and port (17.91.30.246/502 by default), subnet mask (255.255.224.0 by default) and gateway (17.91.1.2 by default) should be changed according to your network environment. RTU Baudrate (default value: 0), parity bit (default value: 1), slave ID (default value: 39) Customer ID: Set to 0
---	---

6. After configuration is finished, check every data in the System BMS are correct as shown below. Verify that the proper number of racks is displayed

2. Installing the Product

ELP MON Ver01.33

COMMAND LOG OPTION

TCP/IP

SYSTEM MONITORING

										UPS	SYSTEM
										SCHNEIDER	136S1P

HeartBeat	Watchdog	Service/Total #1/#1	Service [V]	Service [%]	SYS[V]	SYS[A]	SOC[%]	SOH[%]	Max[CV]	Min[CV]	Max[CT]	Min[CT]
499	0	23.8	0	23.8	0	100	3	2.997	25.68	24.97		

Total ALARM Bit: 00000000/00000000/00000000/00000000/00000000/00000000/00000000/00000000/00000000/00000000

Total MINOR Protection Bit: 00000000/00000000/00000000/00000000/00000000/00000000/00000000/00000000/00000000/00000000

Total MAJOR Protection Bit: 00000000/00000000/00000000/00000000/00000000/00000000/00000000/00000000/00000000/00000000

Digital Input/Output: 00000000/00000000

RACK_INFO | CELL_INFO | Rack #: 001 ~ 010 | 011 ~ 020 | 021 ~ 030 | 031 ~ 040 | 041 ~ 050 | 051 ~ 060 | 061 ~ 070 | 071 ~ 080 | 081 ~ 090 | 091 ~ 100 | 101 ~ 110 | 111 ~ 120 | 121 ~ 130

No#	Mode	Rack[V]	Real[A]	Avg[A]	SOC[%]	SOH[%]	[Alarm]	[Minor]	[Major]	Con_SW	Sen_SW	EXT_SW	ComF##	Avg[CV]	Avg[CT]	Max[CV]	Min[CV]	Max[CT]	Min[CT]	2nd	Loc		
001	Online	23.8	0	0	0	100	0 EA	0 EA	0 EA	0 EA	1 EA	1 EA	0	2.998	25.21	3	2.997	25.68	24.97	<input type="checkbox"/>	<input type="checkbox"/>		
002																					<input type="checkbox"/>	<input type="checkbox"/>	
003																						<input type="checkbox"/>	<input type="checkbox"/>
004																						<input type="checkbox"/>	<input type="checkbox"/>
005																						<input type="checkbox"/>	<input type="checkbox"/>
006																						<input type="checkbox"/>	<input type="checkbox"/>
007																						<input type="checkbox"/>	<input type="checkbox"/>
008																						<input type="checkbox"/>	<input type="checkbox"/>
009																						<input type="checkbox"/>	<input type="checkbox"/>
010																						<input type="checkbox"/>	<input type="checkbox"/>

[Alarm]	00000000/00000000/00000000/00000000/00000000/00000000/00000000/00000000	Con_SW	00000000/00000000
[Minor]	00000000/00000000/00000000/00000000/00000000/00000000/00000000/00000000	Sen_SW	00000000/00000001 MCCB ON;
[Major]	00000000/00000000/00000000/00000000/00000000/00000000/00000000/00000000	EXT_SW	00000000/00000010 Fuse#2 ON;

CONNECTION LOG_CELL LOGGING

Figure 2-97: Check System BMS Items

2.8.14 Communication Check

After installation, wiring, and configuration are completed, you must check the communication status by connecting the TCP/IP cable and run the MODBUS program to see whether the data of the System BMS shows the data of Rack BMS correctly.

2.8.14.1 PC's IP Setting for Communication with the System BMS

	NOTICE
	<ul style="list-style-type: none">▪ The following guide for PC's IP setting is made with Windows 7. Other versions of Windows may be different than the images in this manual.

1. Before checking the Data of the System BMS, you must change IP settings in the notebook PC.
2. Click the **"START BUTTON"** in the desktop's status bar (①) to open the start menu. Click **"Network"** (②). If "Network" menu is not available, click "Control Panel"

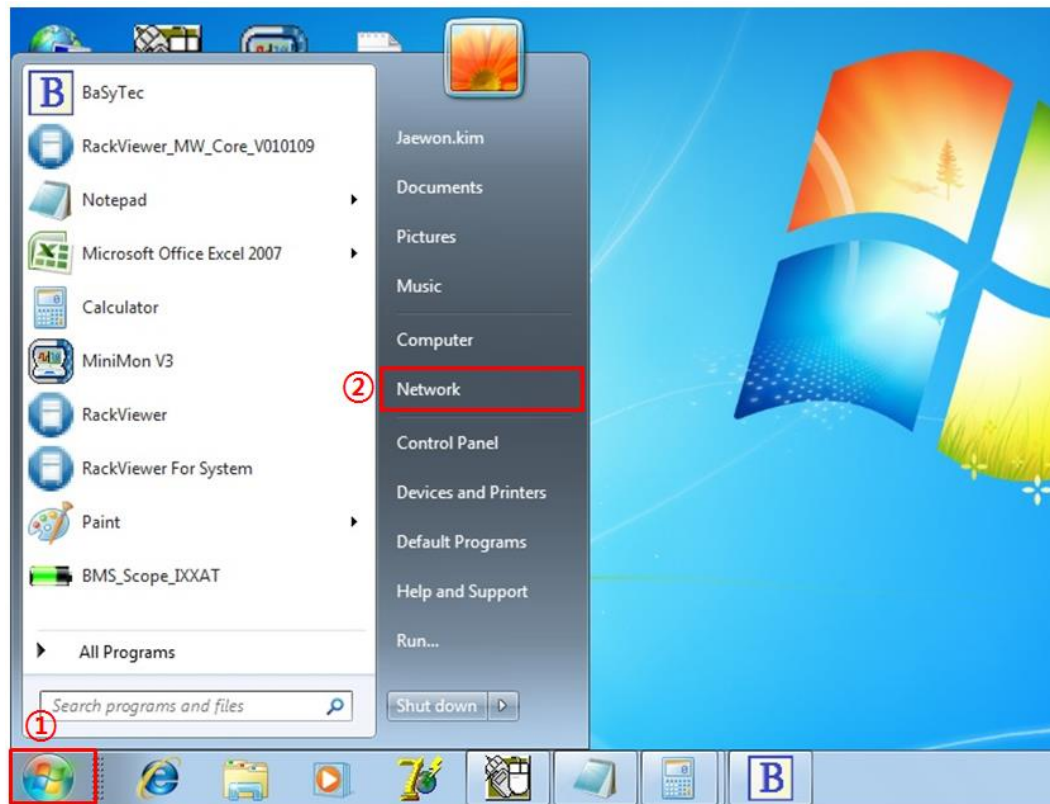

Figure 2-98: Open "Network"

3. When the network window appears, click **"Network and Sharing Center"** (③).

2. Installing the Product

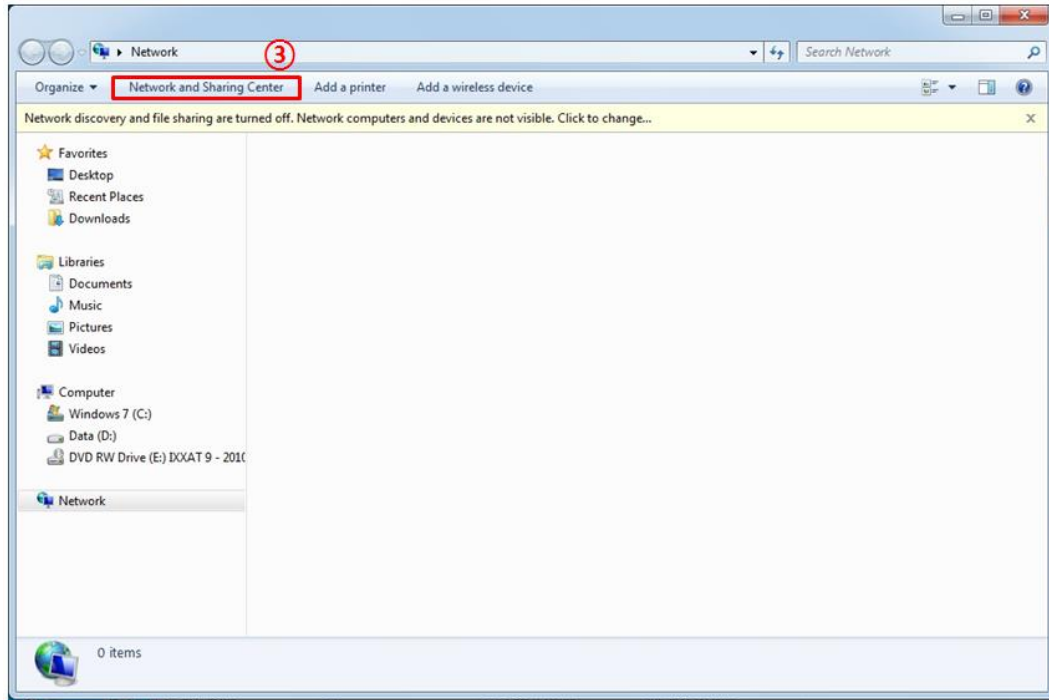

Figure 2-99: Open “Network and Sharing Center”

4. When the following window appears, click “Change adapter settings” (④).

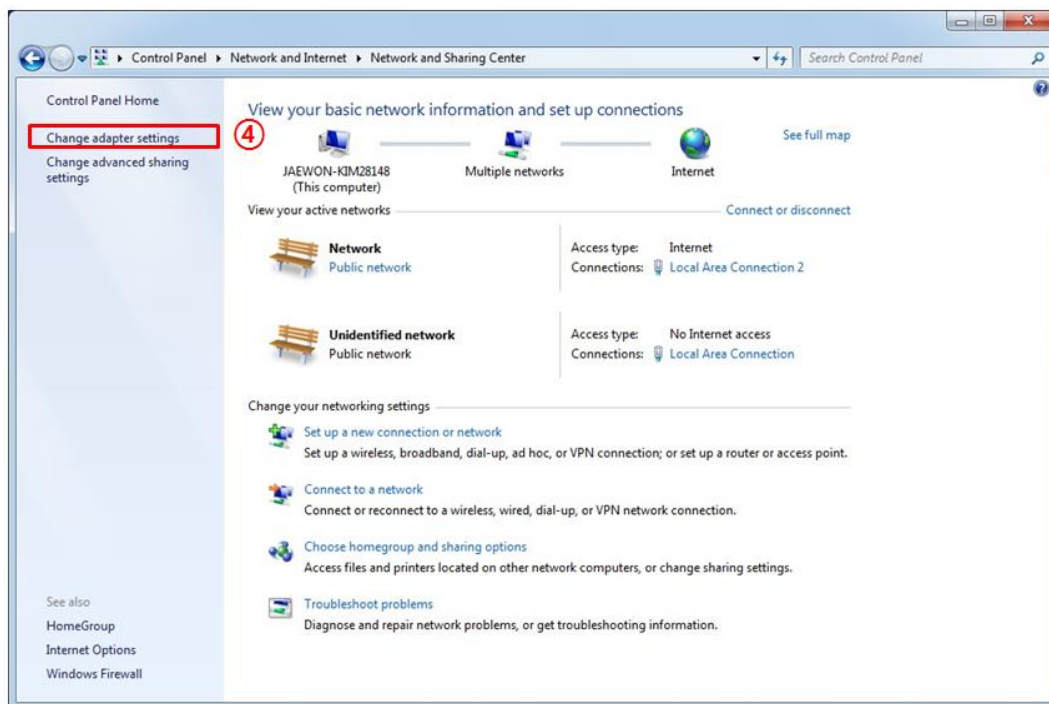

Figure 2-100: Open “Change adapter settings”

- When the Network connections window appears, right-click **“Local Area Connection”** (⑤). When the pop-up menu appears, click **“Properties”** (⑥).

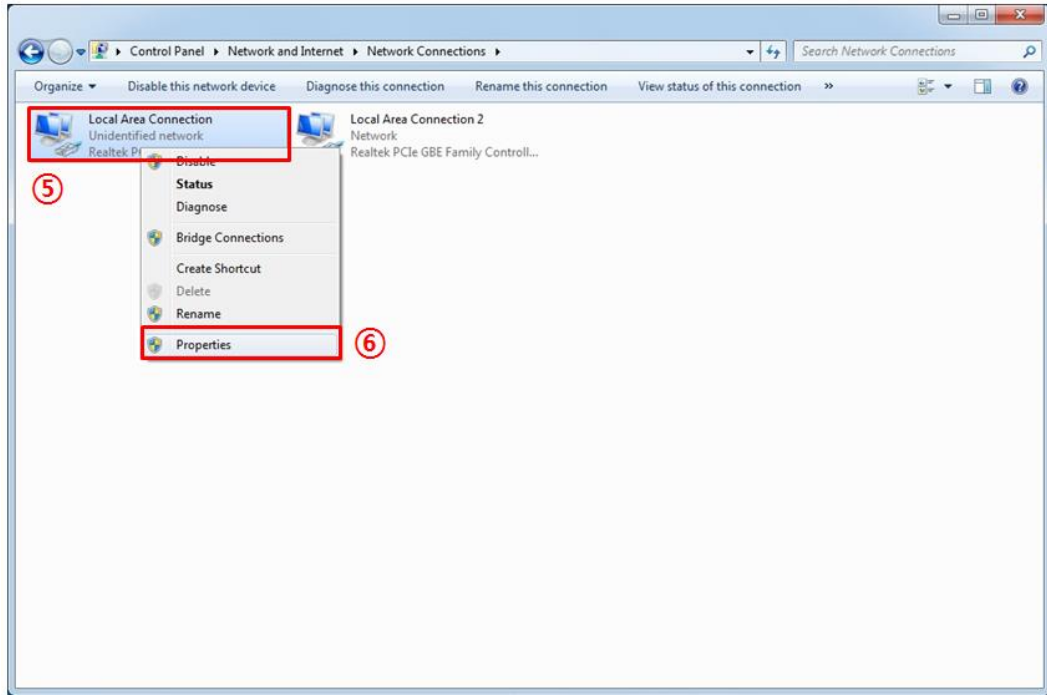

Figure 2-101: Open “Properties” for “Local Area Connection”

- When the Local Area Connection Properties window appears, select **“Internet Protocol Version 4 (TCP/IPv4)”** (⑦) and then click **“Properties”** (⑧).

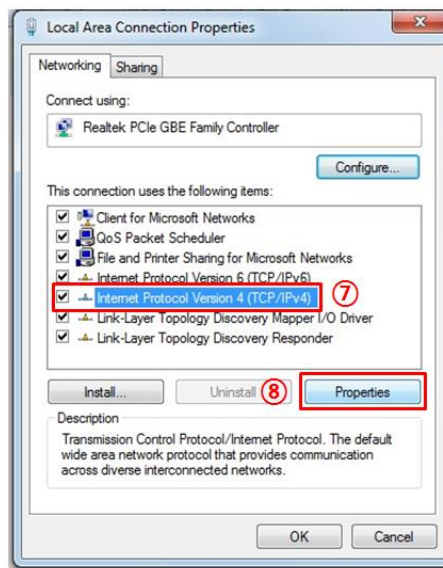

Figure 2-102: Open Properties for “Internet Protocol Version 4(TCP/IPv4)”

2. Installing the Product

7. When the following window appears, change the “**IP address**” that fits the network environment (⑨).

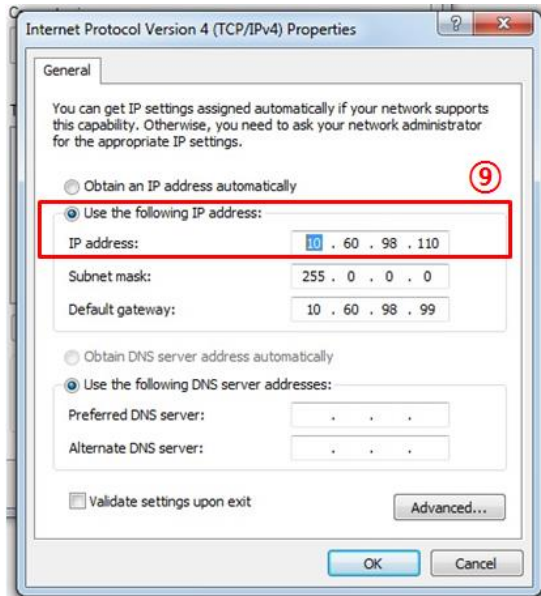

Figure 2-103: Setting the IP address

2.8.14.2 System BMS Data Check

1. Run "ELP_MON.exe." (This program is factory-provided.)

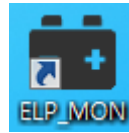

Figure 2-104: System BMS monitoring program icon image

2. When the following window appears, set the following items:

- Settings for TCP/IP and port (①)

Refer to the TCP/IP and port settings entered during System BMS Configuration.

(Section 2.8.13.2, Step 5 on Page 72)

- Number of Racks: Number of racks connected in parallel to the same UPS and connected to same System BMS

- Number of Modules: Number of modules for each rack (e.g., 128S1P Rack has 16 modules)

3. Click Connect (②).

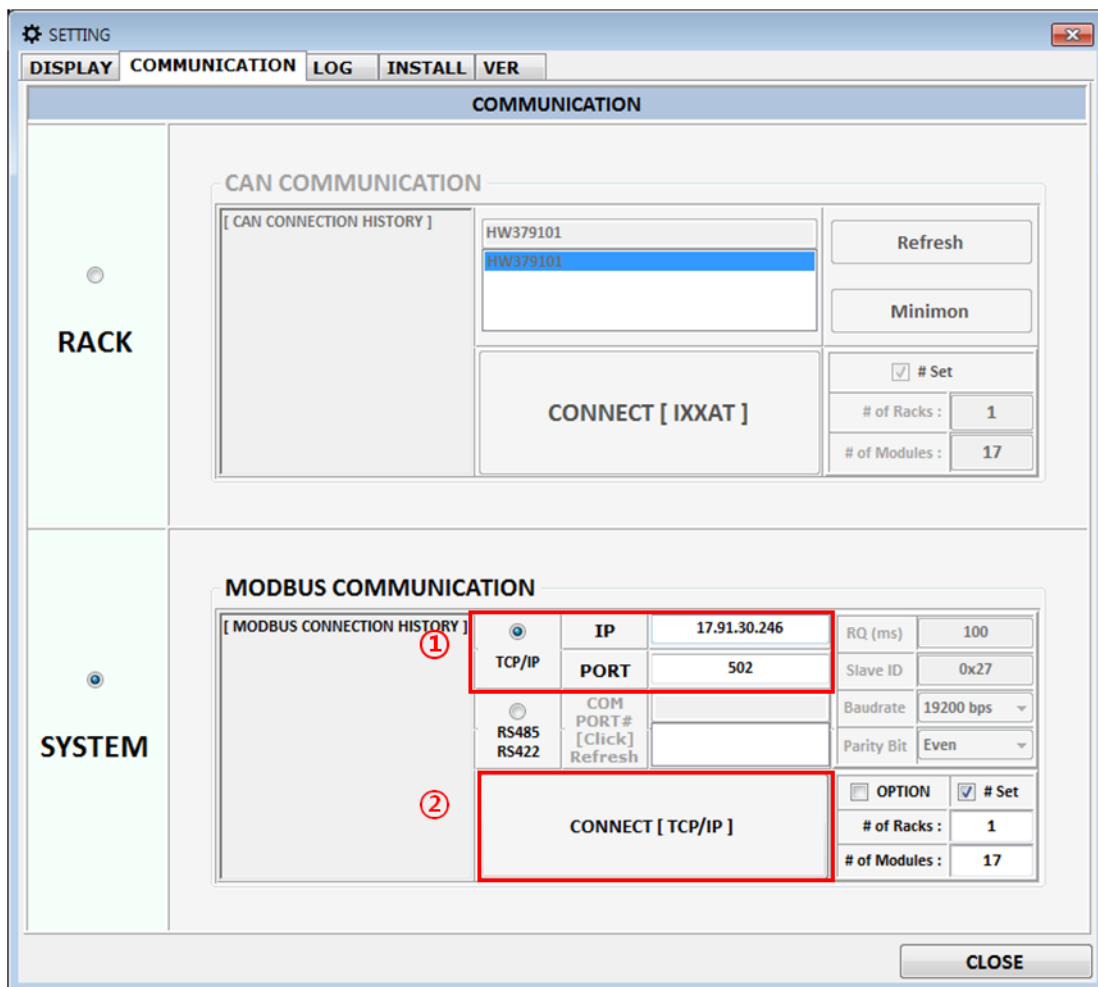

Figure 2-105: Main Window of Monitoring Program

2. Installing the Product

4. Check all the data of the rack (string) in the following window.

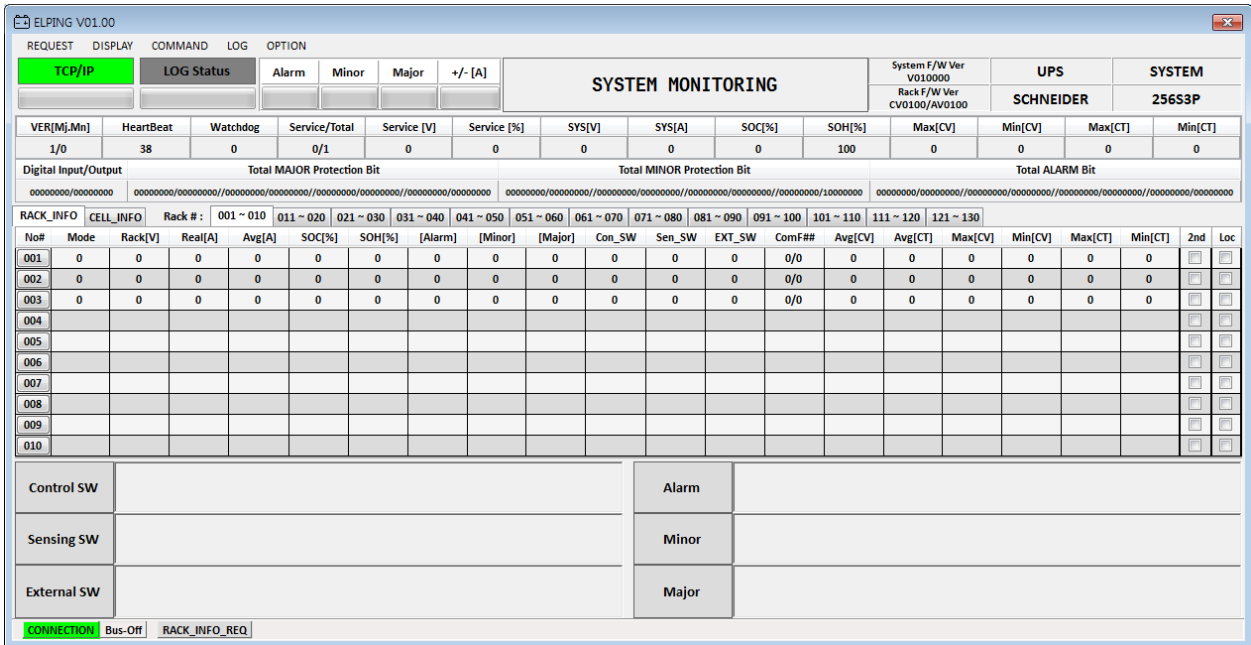

Figure 2-106: Checking System BMS Data

www.SamsungSDI.com